

# Median Handbook Interim Version



The purpose of this document is to guide the professional through the existing rules, standards and procedures, as well as to provide current national guidance on the best ways to plan for medians and median openings.

Unless stated otherwise or specifically referenced, **this is not a set of standards or a Departmental Procedure** but is a comprehensive guide to allow the professional to make the best decisions on median planning.

**The primary thrust of this handbook is the unsignalized median opening.** Even though much of this material can be used with signalized intersection planning, , issues of signalized queues and signal timing are not covered in detail.

Florida Department of Transportation  
State of Florida  
Systems Planning Office  
605 Suwannee St.  
Tallahassee, Florida 32399  
[www.dot.state.fl.us/planning](http://www.dot.state.fl.us/planning)





**PURPOSE**



# Median Handbook

## PURPOSE

### Purpose

*To provide guidance on designing and placing median and median openings.*

The purpose of this document is to guide the professional through the existing rules, standards and procedures, as well as to provide current national guidance on the best ways to plan for medians and median openings.

Unless stated otherwise or specifically referenced, **this is not a set of standards or a Departmental Procedure** but is a comprehensive guide to allow the professional to make the best decisions on driveway planning.

**The primary thrust of this handbook is the unsignalized median opening.** Even though much of this material can be used with signalized intersection planning, , issues of signalized queues and signal timing are not covered in detail.

*Please direct questions and concerns to:*

Gary Sokolow  
 gary.sokolow@dot.state.fl.us  
 850-414-4912

## Acknowledgements

In addition to all the Team members, we would like to recognize the lifelong work of **Dr. Vergil Stover** for the impact his work has had on this document.

The material we used to create this document came from many of the important access management documents written over the last 40 years. Specifically though, we borrowed heavily from the following documents. These documents should be used for further illumination of the guidance in this handbook

**Access Management Manual** (Kristine Williams and Vergil Stover)  
– Transportation Research Board – Center for Urban Transportation Research

**Transportation and Land Development** (Vergil Stover) –  
Institute of Transportation Engineers

## Handbook Contributors:

Theo Petrisch  
Joel Leisch  
Vergil Stover, Center for Urban  
Transportation Research

## Authors/Editors:

Gary Sokolow, Central Office  
Vergil Stover, Center for Urban Transportation Research  
Frank Broen, Teach America

## Statewide Access Management Group:

Antonio Acosta, D-6	Tom Hancock, CO	Marshall Sander, D-2
Gary P. Amig, D-1	Tony Hailey, D-1	Rory Santana, D-6
Rafael deArazoza, D-6	Dan Igelesias, D-6	Jim Scott, D-2
Ingrid Birenbaum, Tpk	Charley Locke, D-3	Judith A. Smith, D-7
Carlos Bonilla, CO	Armando Lopez, D-6	Deborah Snyder, D-1
Felix Blanco, D-6	David Lynch, D-2	Ronald Steiner, D-6
David Burlison, VMS	George Marek, D-5	Greer Stephens, D-3
Donald Cashdollar, D-1	Robert May, Turnpike	Michael Tako
June Coates, D-3	Alex Meitin, D-6	Janak S. Thakkar, D-4
Beth M. Coe, D-4	Jim Mills, CO	Clark Turberville, D-4
Robert Downie, CO	Delfin Molins, D-6	Freddie Vargas
Tom Dyal, D-2	Priscilla D. Moore, D-2	Jack West, D-5
Gary Ewin, D-1	Vicente Noboa, D-4	Jim Wood, D-5
Fred Ferrel, D-5	David W. Olson, D-7	Timothy Whitley, D-2
Ronald Fetzko, D-5	Jonathan Overton, D-4	Donald Witmer, D-1
Terry Fleischner, D-5	Robert Pearce, D-2	Carol Wright, D-2
Jorgr Frases, D-6	Ed Petersen, D-5	
Carleen Flynn, Turnpike	Ray Pippitt, D-4	
Al Gilbranson, D-7	Alan G. Rothmann, D-4	
Javier Gonzalez, D-6	Tony Russo, D-1	
Ed Gassman, D-3		
John Grant, CO		

*District 1 = D-1, etc.  
Central Office = CO*

PURPOSE .....3  
PURPOSE .....3  
    Purpose .....3  
    Acknowledgements .....4  
    Handbook Contributors:.....4  
    Authors/Editors: .....4  
    Statewide Access Management Group: .....4  
Introduction .....9  
INTRODUCTION .....9  
    1.1 Medians and their Importance for safety .....9  
    Why do we use medians? .....9  
    What are the Benefits of Medians? .....10  
    How Do Medians Fit in with Access Management?.....10  
    1.2 11  
    MEDIAN OPENINGS DEFINED — WHAT IS THE FUNCTION OF A MEDIAN OPENING?  
    ..... 11  
    1.3 13  
    CRASH COMPARISON AND PUBLIC OPINION OF ROADS WITH AND WITHOUT  
    MEDIANS ..... 13  
    1.3.4..... 15  
    DEPARTMENT POLICY ON MEDIANS AND MEDIAN OPENINGS ..... 15  
    **Rule 14-97**..... 15  
    Multi-lane Facility Median Policy ..... 17  
    Plans Preparation Manual ..... 17  
    What is the impact of these Standards? ..... 18  
    Median Opening Decision Process ..... 18  
    FDOT Procedure: ..... 18  
    625-010-020 ..... 18  
    District Median Opening Review Teams..... 18  
    Guiding Principles..... 19  
    Minimum Queue Storage Requirements ..... 19  
    Conditions for More Flexibility ..... 20  
    Other Considerations..... 20  
    Conditions for Less Flexibility or Greater Scrutiny..... 21  
    Unfavorable Conditions ..... 21  
    Retrofit from Center Turn Lanes to Restrictive Median ..... 21  
    Other Department Criteria and Standards..... 21  
IMPORTANT CONCEPTS.....23  
IMPORTANT CONCEPTS IN UNDERSTANDING MEDIANS AND MEDIAN OPENING  
PLACEMENT .....23  
    2.1 23  
    IMPORTANCE OF ROADWAY FUNCTIONAL CLASSIFICATION.....23  
    Hierarchal Priority of Median Openings..... 25  
    2.2 26  
    MEDIAN OPENING PLACEMENT PRINCIPLES.....26  
    Median Opening Placement Principles.....26  
    AVOID MEDIAN OPENING FAILURE.....28  
    2.3 PARTS OF THE FUNCTIONAL AREA OF AN INTERSECTION .....29  
    Perception Reaction Time/Distance .....29  
    Right Turn Weave Distance.....29

(Right Turn Weave Offset).....	29
Full Width Median.....	31
Deceleration and Length of the Left-Turn Lane.....	32
Total Deceleration Distance (Includes Taper).....	32
Florida DOT Standard Index #301.....	32
2. 4 Design Speed/Entry Speed.....	33
Entry Speed.....	34
Non-Peak Hour Speeds.....	35
Queue Storage.....	35
Rule of Thumb:.....	37
Queue Length Adjustments for Trucks.....	38
Median Opening Spacing — How All These Factors Impact the Spacing of Openings.....	38
2.4 40	
WHAT DISTANCE IS NEEDED FROM A FREEWAY RAMP TERMINAL TO THE FIRST MEDIAN OPENING?.....	40
2.5 43	
MEDIAN END TREATMENTS.....	43
A Strictly Bullet Nose Opening.....	43
2.5 44	
MEDIAN OPENING LEFT TURN RADIUS.....	44
2.6 45	
MEDIAN OPENING LENGTH.....	45
Excessively Wide Median Opening.....	45
2.7 46	
PAVEMENT MARKINGS AND SIGNING.....	46
Sight Distance.....	47
SIGHT DISTANCE AS IT RELATES TO MEDIANS AND MEDIAN OPENING DESIGN.....	47
3.1 47	
INTRODUCTION TO SIGHT DISTANCE CONCEPTS.....	47
AREA SIZE OF VEHICLE.....	48
TIME OF VISIBILITY.....	48
WHAT IS STOPPING SIGHT DISTANCE?.....	48
3.2 49	
SIGHT DISTANCE FOR SPECIFIC MEDIAN OPENING MANEUVERS.....	49
Turning left through a Median as a Two-Step Maneuver.....	50
Sight Distance for U-Turns.....	51
Sight Distance for Left Turn into Side Street.....	51
Left Turn Lane Offset.....	51
From Plans Preparation Manual.....	52
3.3 54	
LANDSCAPING AND SIGHT DISTANCE ISSUES.....	54
Major Criteria for Decisions on Sight Distance and Planting Area and Spacing in Medians.....	54
Median Width.....	59
MEDIAN WIDTH.....	59
4.1 59	
Function Determines Median Width.....	59
4.2 60	
ANATOMY OF MEDIAN WIDTH.....	60
4.3 60	
Minimum and Recommended Widths.....	60
4.4 61	
SOME EXAMPLES.....	61

4.5 62  
 MINIMUM TRAFFIC SEPARATOR WIDTH AT INTERSECTIONS..... 62

4.6 62  
 PEDESTRIAN CONSIDERATIONS AT TRAFFIC SEPARATORS..... 62

4.7 62  
 SEEING TRAFFIC SEPARATORS AT INTERSECTIONS..... 62

4.8 62  
 MINIMUM MEDIAN WIDTH FOR U-TURNS..... 62

4.9 63  
 DESIGN FOR TRUCKS ..... 63

Special U-Turn Considerations ..... 65

SPECIAL U-TURN CONSIDERATIONS..... 65

5.1 65  
 AASHTO GUIDANCE ON WIDTH AND U-TURNS ..... 65

5.2 66  
 OPTIONS FOR U-TURNS..... 66

1. Wide medians..... 66

2. Median “Bulb-Out” ..... 66

3. Flare-Out (Jug Handles) ..... 67

Two Examples of a Flare..... 67

5.3 69  
 TRUCK U-TURNS ..... 69

Alternatives for accommodating u-turns by large vehicles (such as delivery, trucks and semis) ..... 69

5.4 70  
 U-TURN LOCATIONS ..... 70

U-Turn at Signalized Intersections ..... 70

U-Turns in Advance of a Signal..... 72

U-Turn After Signal..... 73

5.5 75  
 PLACEMENT IN RELATION TO DRIVEWAYS..... 75





**Introduction**

**1**



**INTRODUCTION**

**1.1 Medians and their Importance for safety**

**Why do we use medians?**



Vehicular Safety — to prevent crashes caused by head-on and crossover traffic, headlight glare and traffic turning left.



Pedestrian Safety — to provide a refuge for pedestrians crossing the highway.



Vehicular Efficiency — to remove turning traffic from through lanes thereby maintaining highway operating speed.

Restrictive medians and well designed median openings are known to be some of the most important features in a safe and efficient highway system. The design and placement of these medians and openings is an integral part of the Access Management practice.

## What are the Benefits of Medians?

---

- **Safety**
  - Fewer/less sever accidents
  - Less auto/pedestrian conflict
- **Efficiency**
  - Higher levels of service
  - Less stop and go traffic
- **Aesthetics**
  - More room for landscaping and pedestrians
  - More attractive corridors
  - Less asphalt

---

*Restrictive medians help in both low and high traffic situations, but where traffic is high, the benefits are greater.*

---

Properly implemented median management will result in improvements to traffic operations, minimize adverse environmental impacts, and increase highway safety. As traffic flow is improved, delay is reduced as are vehicle emissions. In addition, roadway capacity and fuel economy are increased, and most importantly, accidents are less numerous and/or less severe.

## How Do Medians Fit in with Access Management?

**Access Management is the location, spacing and design of:**

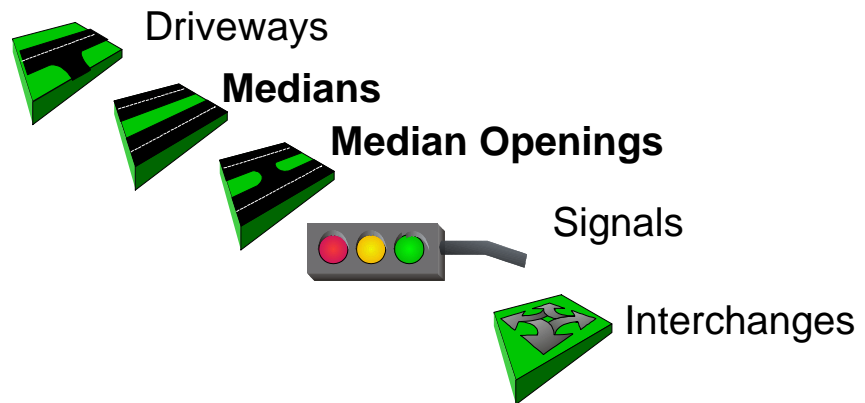

## 1.2

### MEDIAN OPENINGS DEFINED — WHAT IS THE FUNCTION OF A MEDIAN OPENING?

- Median openings provide for cross traffic movement.
- Median openings allow left turns and u-turns from the highway.

NORMAL MEDIAN OPENING

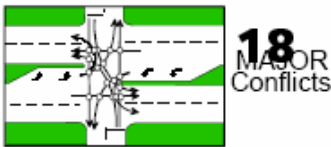

A typical median opening that allows all turns has 18 major conflict point

DIRECTIONAL MEDIAN OPENING

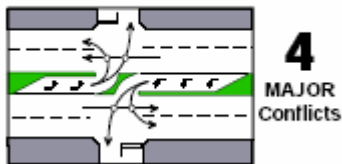

One way to limit the number of conflicts is through the design of median openings. This is a “directional” median opening serving a side street, a design which greatly reduces the conflict points by limiting the number of allowed turning movements.

LEFT-IN ONLY

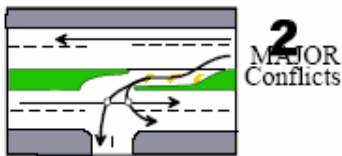

By providing a restrictive median along arterial roads, we can assure that the number of conflict points is kept to the minimum. Through use of restrictive medians, almost every driveway along the corridor essentially becomes a right-in and right-out driveway with only two conflict points.

RESTRICTIVE MEDIAN

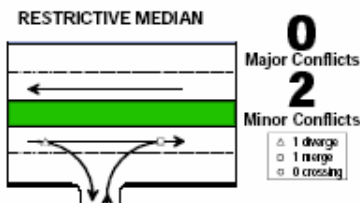

**The location of median openings has a direct relationship to highway efficiency and traffic progression**

To assure efficient traffic operation full median openings should only be at locations which are thoughtfully placed along the highway. If median locations are properly spaced when signalized, traffic can be progressed at efficient and uniform operating speeds.

 **Another Benefit of Longer Opening Spacing**

 **Better speed and progression**



 **Signal Spacing and Speed**

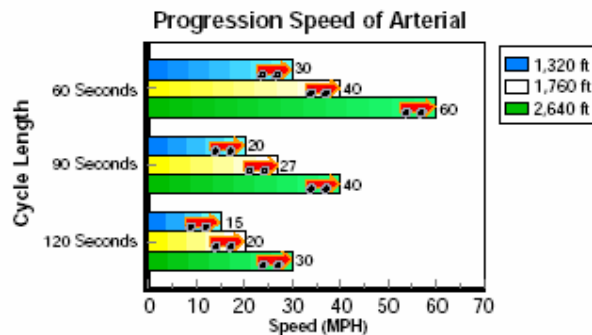

Source: Stover, Demosthenes, Weesner (1991)

*For More Information on Signal Spacing and Progression:*

- NCHRP Report # 348 - **Access Management Guidelines for Activity Centers** (Section 7-3)
- V.G. Stover, P.B. Demosthenes and E.M. Weesner, **"Signalized Intersection Spacing: An Element of Access Management,"** Compendium of Papers, 61st Annual Meeting of the Institute of Transportation Engineers, September 1991.

### 1.3

## CRASH COMPARISON AND PUBLIC OPINION OF ROADS WITH AND WITHOUT MEDIANS

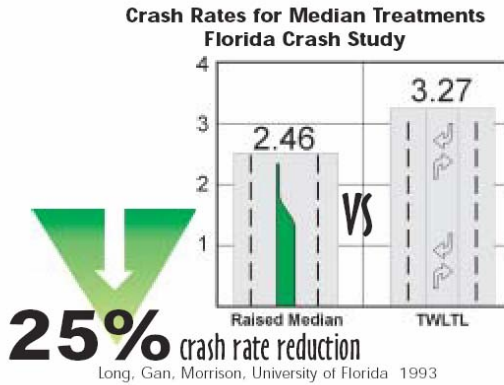

Research has shown that restrictive medians are a large safety benefit. In 1993, an evaluation of urban multilane highways in Florida revealed that the crash rate, where there are restrictive medians is 25% lower than those with center turn lanes.

**Atlanta's Memorial Drive**

**Data**

- 4.3 Miles
- 6 Lanes
- 40,000 to 48,000 Vehicles per Day
- Speed Limit 45 MPH

**Before**

- Two way left turn Lane

**After**

- Raised Median (14 ft width)
- 14 Median Openings Provided
- 7 public streets were not given median openings
- U turns allowed at all openings but one

Some in the field complained that comparing the restrictive median roadways with those roadways with center turn lanes was an unfair comparison because they felt that the center turn lane facilities were in areas with a high percent of left turns, and that most crashes are caused by left turns. In the early 1990's Georgia DOT sponsored, "before and after" research on a Memorial Drive, a particularly hazardous section of roadway in the Atlanta area (DeKalb County).

**Memorial Drive Crash Findings**

**Mid-Block Crashes**      **Intersection Crashes**

**- 55%**      **- 24%**

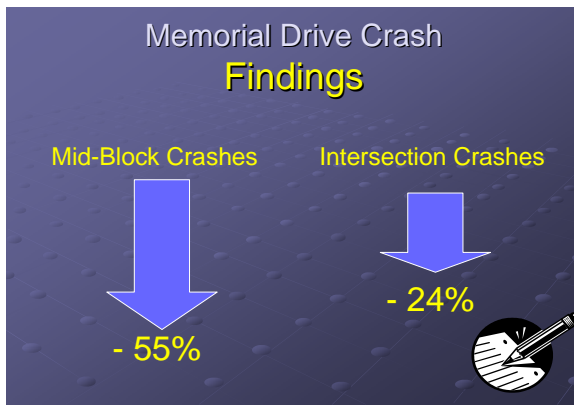

The research clearly showed that not only did mid-block crash rates go down, as expected, but intersection crashes decreased significantly. Forcing more left turn traffic through a few openings was expected to increase the crash rate, but hopefully decrease the severity. But the opposite proved to be true.

**Center Turn Lane Driver Perspective**



Focus Areas - 3  
Source: Sean Brown, Crum and NYDOT

The researchers in the Georgia study felt that the decrease in intersection crashes, even though traffic volumes increased at intersections, was that the "Driver Information Load" was decreased by having well placed and visible median openings. These increase driver expectancy as shown in the exhibits

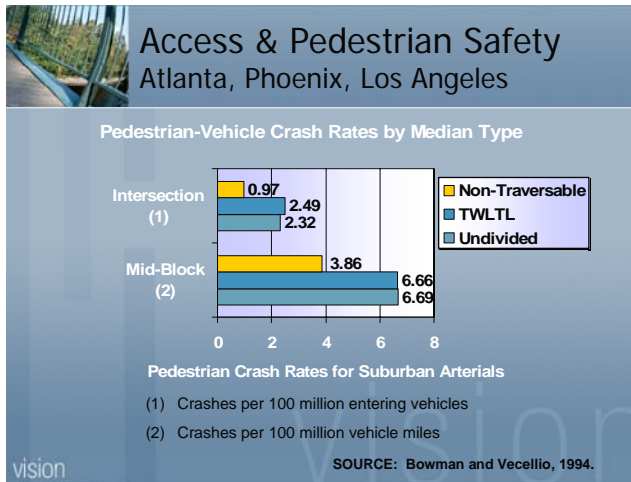

Other research has shown that the presence of restrictive medians makes the environment safer for pedestrians.



When medians are constructed, they can be designed with the pedestrian in mind. Here's an example from Colorado where a pedestrian cross over was made part of the design to more easily allow neighborhood walkers to cross this multilane roadway.



### 1.3.4

## DEPARTMENT POLICY ON MEDIANS AND MEDIAN OPENINGS

### Rule 14-97

Administrative Rule Chapter 14-97 establishes the seven classifications for state highways and the criteria and procedures for assigning these classifications to specific roads. These classifications contain separation standards for access features. Essentially, the Department of Transportation determines which roads are the most critical to providing high speed, high volume traffic, and these end up with the highest of standards.

Medians and median openings are regulated through the requirement for a restrictive median in certain classes. For those classes, spacings between median openings are regulated. The Median Opening Spacing Standards and how these are measured are found in the following Figures.

### Access Management Standards From Rule 14-97

Class	Medians	Median Openings		Signal	Connection	
		Full	Directional		More than 45 MPH Posted Speed	45 MPH and less Posted Speed
2	Restrictive w/Service Roads	2,640	1,320	2,640	1,320	660
3	Restrictive	2,640	1,320	2,640	660	440
4	Non-Restrictive			2,640	660	440
5	Restrictive	2,640 at greater than 45 MPH Posted Speed	660	2,640 at greater than 45 MPH Posted Speed	440	245
		1,320 at 45 MPH or less Posted Speed		1,320 at 45 MPH or less Posted Speed		
6	Non-Restrictive			1,320	440	245
7	Both Median Types	660	330	1,320	125	125

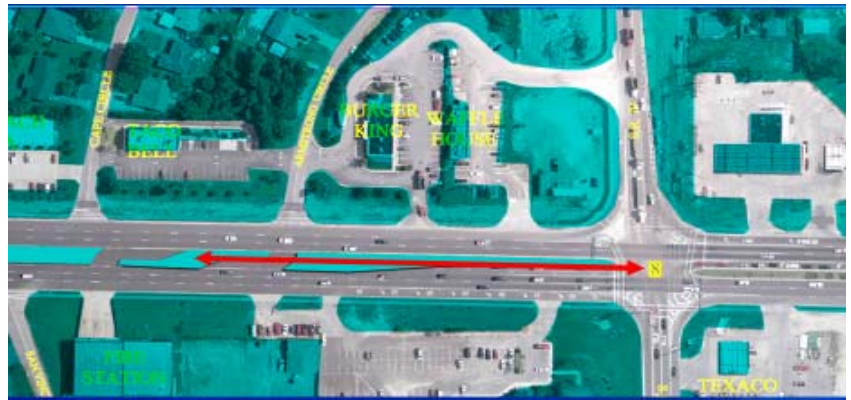
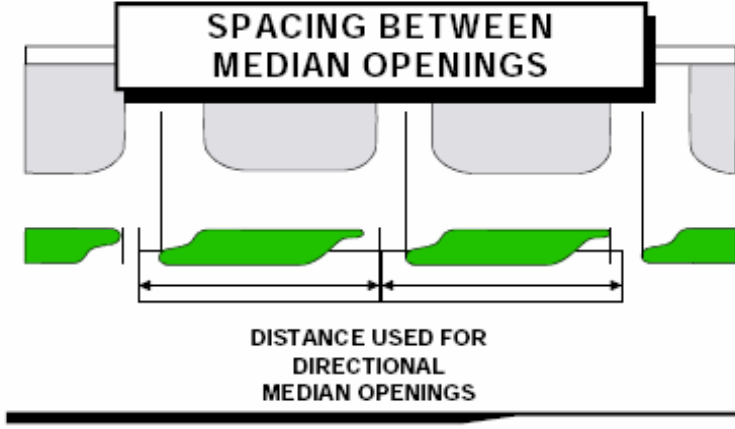



**Multi-lane Facility  
Median Policy  
Plans Preparation  
Manual**

**2.2.2 Multilane Facility Median Policy**

All multilane facilities shall be designed with a raised or restrictive median except four-lane sections with design speeds of 40 mph or less.

Facilities having design speeds of 40 mph or less are to include sections of raised or restrictive median for enhancing vehicular and pedestrian safety, improving traffic efficiency, and attainment of the standards of the Access Management Classification of that highway system.

Topic #625-000-007 January 1, 2006  
Plans Preparation Manual,  
Volume I - English Design Geometrics and Criteria 2-18

Since 1993, the **Multi-lane Facility Policy** essentially directs all Department multilane projects over 40 mph in design speed to have a restrictive median.

It also directs our designers to find ways to use restrictive medians in all multi-lane projects, even those below the 40 mph design speed.

An example of a small pedestrian refuge that could be used on a 5-lane section is shown in the following Figure.

**What is the impact of these Standards?**

One of the impacts of these standards is the concentration of more left turn and more U-Turns. These are things that need to be handled by careful planning and design. In response to this, the Department created the Median Opening Decision Process.

**WHAT IS THE IMPACT OF THESE STANDARDS?**

 **Greater Concentration of Left and U-Turns**

**HOW DO WE DEAL WITH THE CONCENTRATION OF LEFT AND U-TURNS?**

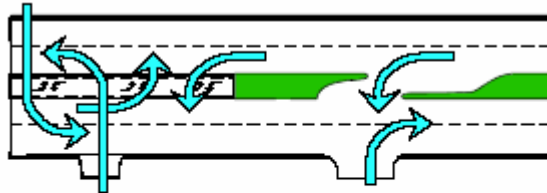





Well designed, well placed median openings

**Median Opening Decision Process  
FDOT Procedure:  
625-010-020**

Meeting the median opening spacing standards of Rule 14-97 can, at times, pose a practical problem. Therefore the Department created a process to analyze deviation from the standards found in the rule. The process allows Project Managers a 10% deviation from the standards for full median openings and gives complete flexibility to Project Managers on decisions involving directional median openings as long as they meet minimum traffic engineering standards for storage, deceleration, sight distance and maneuverability. All deviations greater than this must go to a district Median Opening Review Team for further study and recommendation.

**MINOR DEVIATIONS (MEDIAN OPENING SPACING)**

-  **Decision can be made by responsible engineer**
-  **10% for "Full" openings**  
District can be more strict
-  **Directional openings - "case-by-case"**
-  **Remember:**  
even less than 10% deviations might be a problem



**District Median Opening Review Teams**

Each District has a Median Opening Review Team to consider deviations from Rule 14-97 standards but, safety, traffic efficiency and functional integrity of the highway system must be taken into account.

## Guiding Principles

The decisions of the District Median Opening should be made with the following principles of the process:



**Safety of the entire transportation system**  
*(not just the State system)*



**Traffic Efficiency**

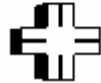

**Functional Integrity**

### Minimum Queue Storage Requirements

- A critical measure for good median opening design is left turn queue storage.
- Site or project specific projections of queue storage should be use at all major or critical intersections. (Due to the variable nature of left turn demand, actual turn volumes should be reviewed in many cases. Designs should also be conservative enough to handle some of the uncertainty in demand.)

Where left turn volume is unknown and expected to be minor

- Urban/suburban minimum = 4 cars or 100 ft.
- Rural/small town minimum = 2 cars or 50 ft.

#### Sources:

- Plans Preparation Manual Vol. I - 2.13.2 Queue Length for Unsignalized Intersections
- Median Opening Decision Process (FDOT) Topic No.: 625-010-020

#### RECOMMENDED QUEUES

 **As measured or projected by traffic study,**

 **4 cars urban minimum**



 **2 cars rural or small town**



**unless it serves a major generator**  
(large discount store, shopping center, etc.)

## Conditions for More Flexibility

The process also gives guidance for where more flexibility (or less) should be considered. Conditions that may be viewed favorably in evaluating a proposed median opening deviation include:

- Opportunities to alleviate significant traffic congestion at existing or planned signalized intersections
- Opportunities to accommodate a joint access serving two or more traffic generators
- Existence of un-relocatable control points such as bridges, waterways, parks, historic or archaeological areas, cemeteries, and unique natural features
- Where strict application of the median opening standards in 14- 97.003(1) Figure 2, would result in a safety, maneuvering, or traffic operational problem
- Where directional opening would replace existing full service median opening.

*Source: Median Opening Decision Process (FDOT)*

### ✓ Favorable conditions

◆ Alleviate significant congestion?

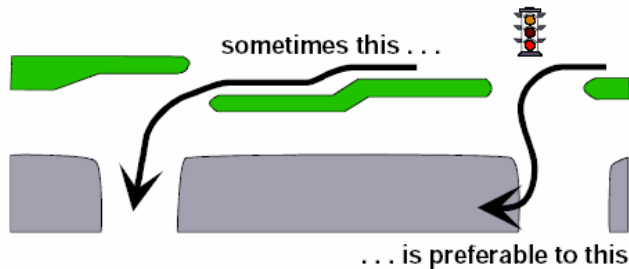

### ✓ Favorable Conditions

◆ Alleviate **significant** congestion?

◆ Encourage joint access

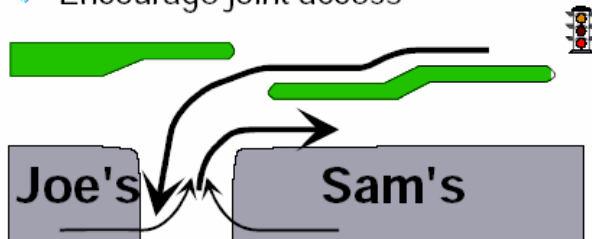

## Other Considerations

- Un-relocatable or unique historic features
- Where strict adherence would cause safety problem
- Where a directional would replace a “full” opening
- Emergency vehicle openings

**Conditions for Less Flexibility or Greater Scrutiny**

- The Strategic Intermodal System (SIS) and the Florida Intrastate Highway System (FIHS)
- Facilities Access Class 2 or 3
- Full median openings and signal spacings
- Median openings in a high accident corridor or location, unless a safety benefit can be clearly shown
- Situations where circulation can be provided through other alternatives

Unfavorable Conditions



- Where any unsignalized intersection would be unsafe (such as close to the Interchange at SR 436 and I-4 in Altamonte Springs)
- Openings in functional area of intersection
- High crash locations
- Where alternatives exist

*Source: Median Opening Decision Process (FDOT)*

**Retrofit from Center Turn Lanes to Restrictive Median**

Existing 5 lane sections on the FIHS and those facilities over 28,000 in daily traffic should be given the highest priority for retrofit.

**All 7 lane sections should be given a high priority for retrofit.**

**Other Department Criteria and Standards**

Other Department documents containing important standards and criteria for medians and median opening design are:

- Plans Preparation Manual
- Standard Index
- Florida Highway Landscape Guide



**IMPORTANT CONCEPTS**

**2**

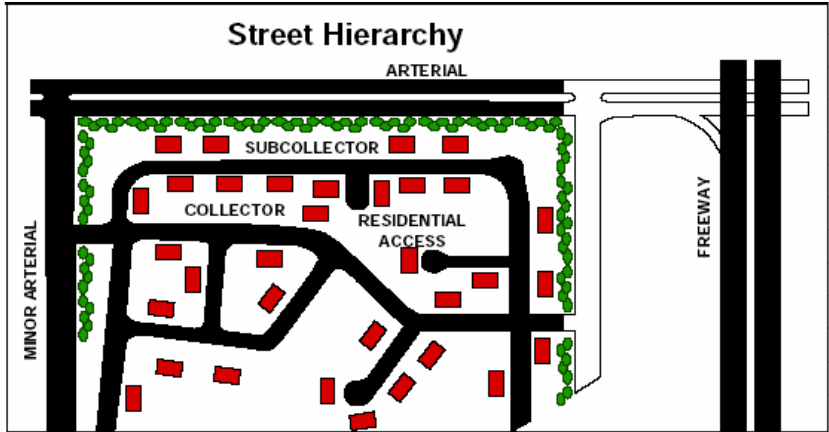

IMPORTANT CONCEPTS IN UNDERSTANDING MEDIANS AND MEDIAN OPENING PLACEMENT

**2.1**

**IMPORTANCE OF ROADWAY FUNCTIONAL CLASSIFICATION**

Highway functional classification means classifying highways with respect to the amount of access or movement they are to provide and then designing and managing each facility to perform that function.

*“The failure to recognize and accommodate by suitable design each of the different trip stages of the movement hierarchy is a prominent cause of highway obsolescence.” AASHTO Green Book (Chapter 1)*

There is no definite dividing line between each of the classes or rigid rules defining what makes a street a local, collector, or arterial. The three basic functional classes represent a continuum of facilities that range from unrestricted access (no through traffic) to complete access control (no local traffic).

An important access management principle is that roads should not connect directly to another of a much higher classification. For instance, a local road may be connected to a major collector, and a major collector may be connected to a minor arterial, but a local road should not connect directly with a major arterial. See the following Figure for illustration of this principle.

Full median openings serve a “Major” transition function. This means that on arterial roads they should only be provided at arterial junctures of the road system as defined for the public street or internal circulation systems.

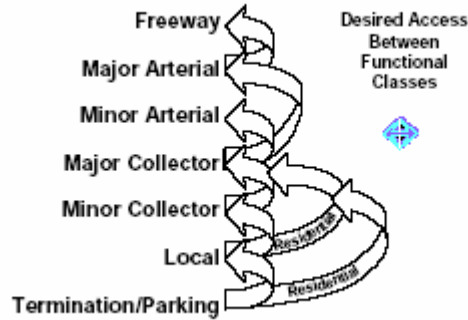

**ROADWAY FUNCTION CLASSIFICATION**

INTERSTATES	<b>THRU TRAFFIC MOVEMENT</b>	CLASS 1
INTRASTATES		CLASS 2
ARTERIALS		CLASS 3
		CLASS 4
		CLASS 5
OTHER		CLASS 6
ARTERIALS		CLASS 7
COLLECTORS	<b>ACCESS TO PROPERTY</b>	
ACCESS ROADS		
LOCAL ROADS		





---

***“Openings should only be provided for street intersections or for major developed areas”***  
*(AASHTO Green Book)*

---

In keeping with the principles of functional design adopted by the AASHTO Green Book, the choice of which opening is to be closed in order to resolve the inadequate length of another requires that the hierarchy (importance) of the median openings be established. The following is a suggested hierarchy of median openings.

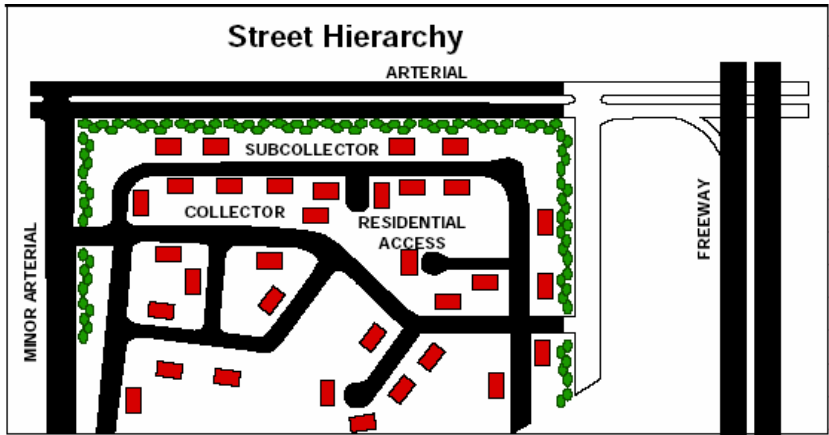



### Hierarchal Priority of Median Openings

Priority of 1A and 1B are the same.

**1A Arterial intersection of freeway ramp**

**1B Major arterial-to-major arterial**

- 2 Other signalized intersections (public street or private access connection) which conform to the signalized intersection spacing standard
- 3 Other intersections on major arterials which conform to the signalized intersection spacing standard but which are not as yet signalized
- 4 Signalized intersections (public street or private access connection) which do not conform to the signalized intersection standard
- 5 U-turn or left-turn/u-turn opening serving 2 or more public and/or private connections. If two such conflicting openings each serve 2 or more connections, the one with the higher volume would typically be given the higher priority . If the volumes are similar, the median opening serving the larger public street volume would be given the higher priority.

Other U-turn/left-turn ingress should normally be given priority over left turns out egress because ingress capacity is higher and produces less conflict than the left turn out movement.

**Source:** Adapted from the course material notes of Virgil Stover.

*For More Information on Roadway Hierarchy:*

- AASHTO Green Book, Chapter 1.
- Transportation and Land Development, Stover/ Koepke

## 2.2

### MEDIAN OPENING PLACEMENT PRINCIPLES

---

*The basic concept used in median opening location and design is avoidance of unnecessary conflicts which result in crashes.*

---

The unsignalized median opening is essentially an intersection. Properly designed it will have an auxiliary lane allowing the left turning vehicles to decelerate without interfering with the through movements of the leftmost through lane.

**Important: The through lane is where the fastest traffic is.** This means that the potential of high speed crashes is the greatest there. Before any design of this area can be done, it is important to know what speed, maneuvering distances, and storage requirements you should design for.

#### Median Opening Placement Principles

- **Follow the spacing criteria in Rule 14-97 as close as possible.**
- **Median openings should not encroach on the functional area of another median opening or intersection.**

Median Openings Should not be in Functional Area

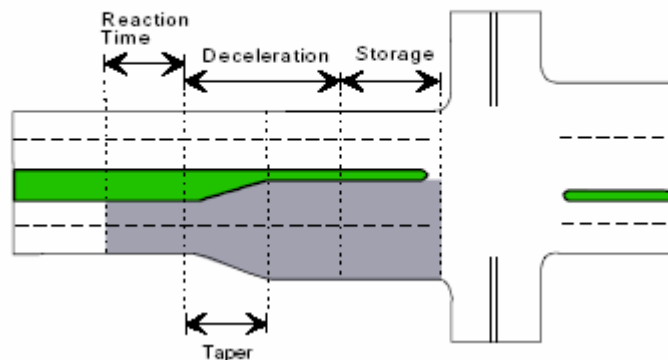

---

*“Driveways should not be situated within the functional boundary of at-grade intersections. This boundary would include the longitudinal limits of auxiliary lanes.”*  
AASHTO Green Book

---

### Median Openings That Allow Traffic Across Left-Turn Lanes Should Not Be Allowed



A median opening within the physical length of a left-turn bay as illustrated in the Figure is potentially dangerous. Such an opening violates driver expectancy.

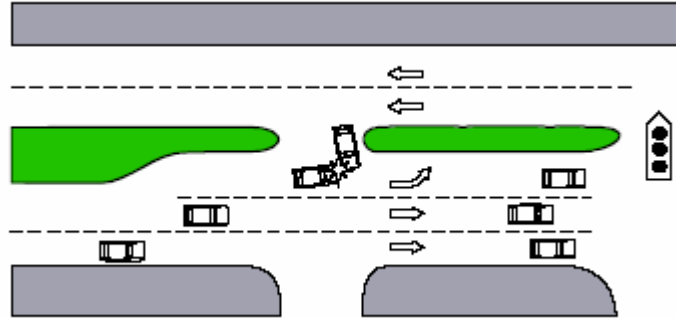

### Median openings that allow the following movements should be avoided

- across exclusive right turn lanes
- across regularly forming queues from neighboring intersections

Avoid openings across right turn lanes due to the danger of queues building up across the opening area. The problem here is that when these queues build, “Good Samaritans” might allow the left turner through only to crash with a vehicle moving freely in the separate right turn lane.

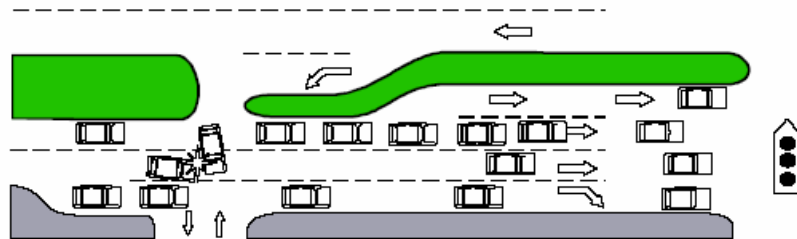

*Exclusive right-turn lanes are most appropriate under the following conditions:*

1. *No median openings interfere,*
2. *The right-turn lane does not continue across intersections, and*
3. *No closely spaced high volume driveways.*

**AVOID MEDIAN OPENING FAILURE**

Median opening failure can occur when critical features of the functional area of the opening are not designed appropriately. This is usually due to the inadequate space for left turn storage. This can either result in excessive deceleration in the through lane, because cars are stored in the needed deceleration length of the functional area. Or, if it is critically under-designed it can lead to cars “hanging out” in the through lane for an even more hazardous situation.

**WHAT IS MEDIAN OPENING FAILURE?**

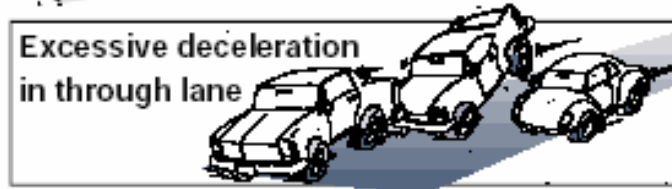

**THROUGH LANE QUEUE BLOCKS ENTRY INTO THE LEFT-TURN LANE**



*Watch out for this problem*

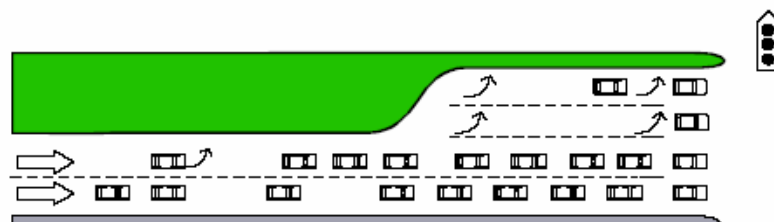

When the queue in the through traffic lane spills past the left-turn bay, turning vehicles are trapped in the queue, as illustrated in this figure. The left-turning vehicles are not able to move into the turn bay until the queue advances. Dual left turn lanes may be more prone to this problem.

**2.3 PARTS OF THE FUNCTIONAL AREA OF AN INTERSECTION**

Perception Reaction Time/Distance

The functional area consists of distance traveled during perception reaction time, plus deceleration distance, plus queue storage.

The perception-reaction time required by the driver varies. For motorists who frequently use the street this may be as little as one second or less. However, unfamiliar drivers may not be in the proper lane to execute the desired maneuver and may require three or more seconds.

Suggested Perception/Reaction distance may be used as follows:

**Suggested Perception and Reaction Distance**

Area	Seconds	35 MPH	45 MPH	55 MPH
Rural	2.5	130 ft	165 ft	200 ft
Suburban	2.0	100 ft	130 ft	160 ft
Urban	1.5	75 ft	100 ft	120 ft
For More Information On Perception-Reaction Time: AASHTO Green Book				

Right Turn Weave Distance  
(Right Turn Weave Offset)

Vehicles turning right from a downstream driveway will need distance to weave if they are turning left at the next opening

The following exhibit shows the potential conflicts from having driveways too close to median openings.

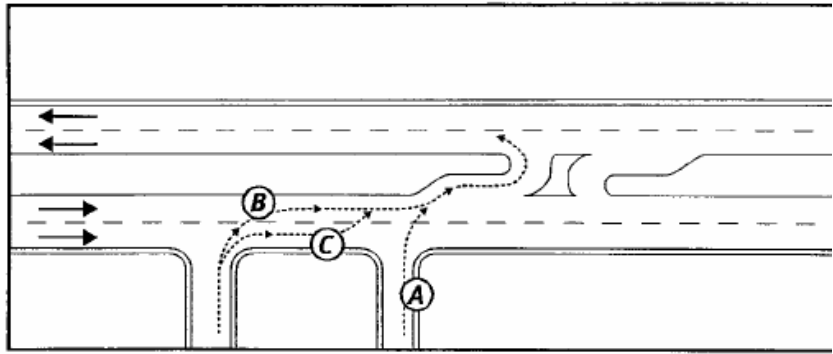

**Weaving Patterns**

- A Short separation:**  
Drivers select a suitable simultaneous gap in all traffic lanes and then make a direct entry into the left-turn/u-turn lane
- B Long separation, low volume approaching from the left:**  
Drivers select a simultaneous gap in all traffic lanes, turn right, and make a direct entry maneuver into the left through lane
- C Long separation, high volume or low volume and high-speed traffic from the left:**  
Drivers wait for suitable gap, turn right, accelerate and make a lane change maneuver, then decelerate as they enter the left-turn lane

**Source:** NCHRP 420 Impacts of Access Management Techniques - 1999

A study, “*Determination of the Offset Distance between Driveway Exits and Downstream U-turn Locations for Vehicles making Right Turns Followed by U-turns*” gives us some guidance for the needed right turn offset or weaving distance needed. See the following exhibit for a picture of the “offset distance”.

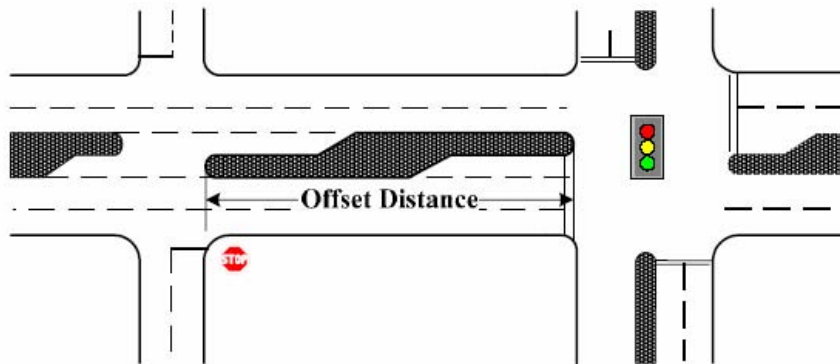

**Source:** *Determination of the Offset Distance between Driveway Exits and Downstream U-turn Locations for Vehicles making Right Turns Followed by U-turns* –University of South Florida, November 2005 - Jian John Lu, Pan Liu, and Fatih Pirinccioglu

Even though the study focused on the weaving made by vehicles positioning for a U-turn, the distances recommended are transferable since the movement to get into a left turn lane is the same maneuver as the one for a U-turn. The research pointed to the fact that the more lanes you have, and the existence of a traffic signal necessitates longer offset distances to safely and efficiently move the left of U-turning traffic.

### Recommended Offset Distances from the Research

U-turn Location	Number of Lanes	Offset Distance (ft.)
<b>Median Opening</b>	4	400
	6 or more	500
<b>Signalized Intersection</b>	4	550
	6 or more	750

**Source:** *Determination of the Offset Distance between Driveway Exits and Downstream U-turn Locations for Vehicles making Right Turns Followed by U-turns* –University of South Florida, November 2005 - Jian John Lu, Pan Liu, and Fatih Pirinccioglu

#### Full Width Median

Where at all possible, you should try to get the perception-reaction distance as a full width of median. This allows a larger portion of median which will be more visible to the driver. This also gives more area for traffic signs and landscaping.

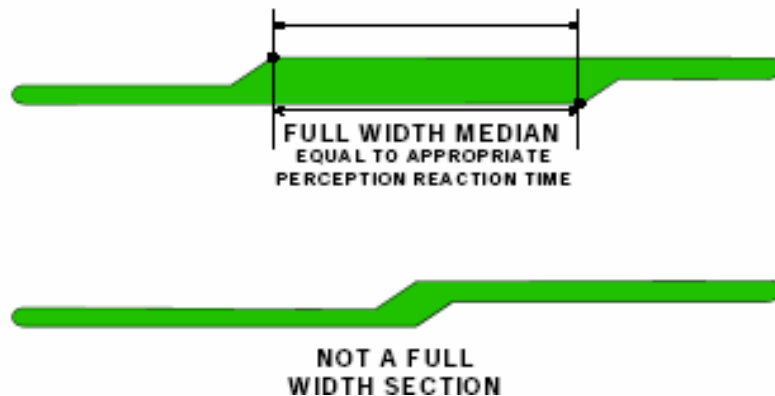

## Deceleration and Length of the Left-Turn Lane

**Taper** — The Taper is the portion of the median opening that begins the transition to the turn lane. Standard Index #301 contains the standards for this feature.

Design standards for left turn lanes are available from several sources, most of which base their rate of taper on approach speed; the faster the speed, the longer the taper. The FDOT does offer standards for the design of left turn lanes. The FDOT Standards Index dictates the use of a 4:1 ratio for bay tapers on all multilane divided facilities regardless of speed. This may be an abrupt transition area, however, most urban areas will benefit from a longer storage area. Urban speeds are generally lower which lessens the need for gradual tapers.

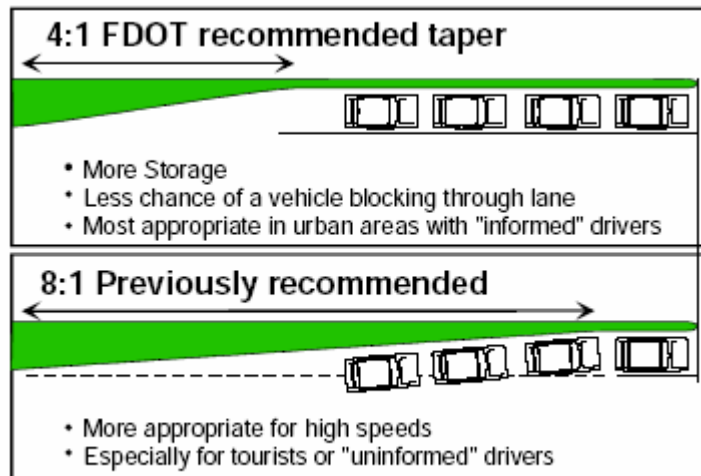

## Total Deceleration Distance (Includes Taper)

Florida DOT Standard Index #301

Minimum standards for the distance needed to properly slow a vehicle down, and bring the vehicle to the storage portion of the median opening is found in Standard Index #301. This distance is measured from the beginning of the taper to the end of the queue storage portion.

The standards found in the Standard Index however should be considered a minimum because research has shown reactions vary considerably with drivers. And in many cases, more space may be needed.



## MEDIAN OPENINGS SHOULD NOT BE IN FUNCTIONAL AREA

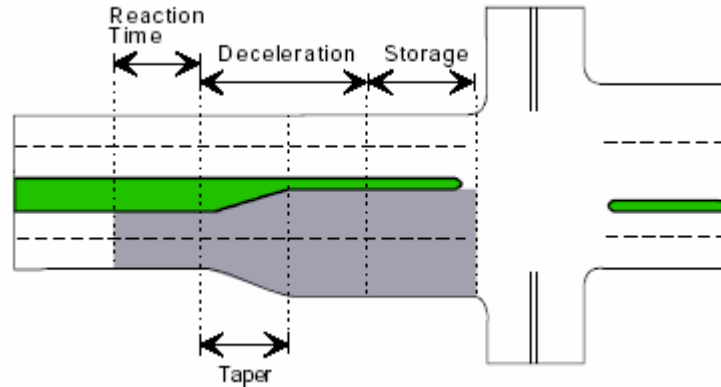

### 2. 4 Design Speed/Entry Speed

The design speed is the speed used to make critical decisions on the roadway design features. The AASHTO Green Book defines the design speed as:

---

*“Design speed is the maximum safe speed that can be maintained over a specified section of highway when conditions are so favorable that the design features of the highway govern.”*

---

The Green Book also makes the following statements regarding the design speed.

---

*“Once selected, all of the pertinent features of the highway should be related to the design speed to obtain a balanced design. **Above-minimum design values should be used where feasible.**” (emphasis added)*

---

## Entry Speed

When considering medians and median openings, the greatest use of **design speed** is for determining the length of right and left turn lanes. A reading of the FDOT Standard Index #301 will show that design speed or the related entry speed are the basis for determining the minimum length of the turn lane for deceleration and stopping behind the turn lane queue.

Deceleration Distances from the Design Standards Index #301		
Design Speed (MPH)	Entry Speed (MPH)	Total Deceleration (ft)
35	25	145
45	35	185
50 Urban	40	240
50 Rural	44	320
55 Rural	48	385

### Total Deceleration Distance — Why Do We Care About Deceleration Distance?

The turn bay should be designed so that a turning vehicle will develop a speed differential (through vehicle speed minus the entry speed of turning vehicle) 10 MPH or less at the point it clears the through traffic lane. The length of the bay should allow the vehicle to come to a comfortable stop prior to reaching the end of the expected queue in the turn bay.

#### EXCESSIVE DECELERATION

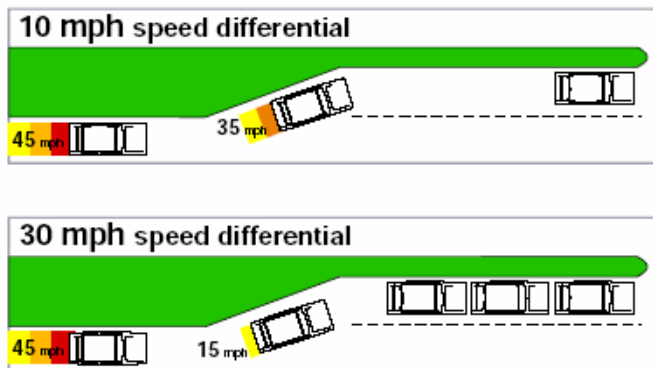

If the turn bay is too short, or queued vehicles take up too much of the deceleration distance, there will be excessive deceleration in the through lane. This creates a high crash hazard as seen in research.

## CRASHES AND SPEED DIFFERENTIAL

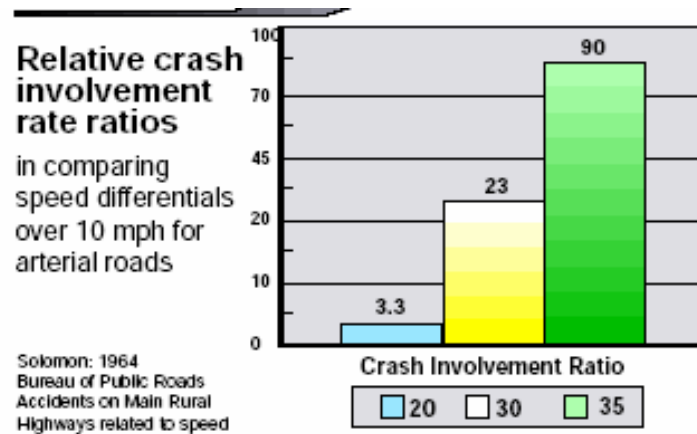

### Non-Peak Hour Speeds

Non-Peak Hours are also important considerations since around 80% of the daily traffic takes place at that time, usually at higher speeds. Turning volumes are lower at those times which will make queuing requirements smaller.

*For More Information on Speed Definitions:*

- Design Speed, Operating Speed, and Posted Speed Practices, NCHRP Report 504, 2003
- AASHTO Green Book

### Queue Storage

Turn lanes must include adequate length for the storage of traffic waiting to turn. This is also called turn lane queue length. Where a specific queue study does not exist, the Florida Department of Transportation will normally require a minimum of a 100 ft. queue length (four passenger cars) in an urban/suburban area and a 50 ft. (two passenger cars) queue length in rural or small town areas.

#### Sources:

- Plans Preparation Manual Vol. I - 2.13.2 Queue Length for Unsignalized Intersections
- Median Opening and Access Management Decision Process (FDOT) Topic No.: 625-010-020

The AASHTO Green Book suggests the use of a 2 minute interval for unsignalized locations. The following Figure illustrates that where the average queue is 2 vehicles, the actual queue will probably be over 2 vehicles much of the time.

## HOW CAN DESIGNING TO THE AVERAGE FAIL?

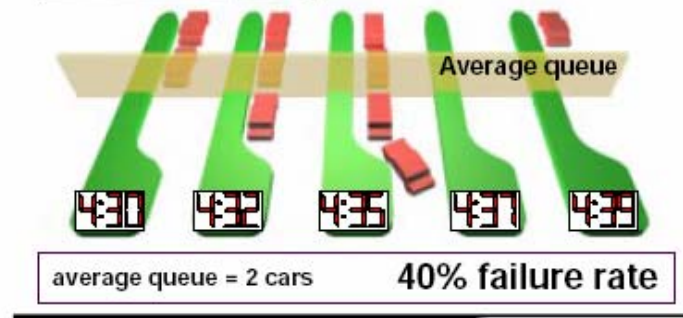

The technique used to analyze this distribution of queue length is the Poisson Distribution. The Poisson Distribution is used to predict randomly occurring discrete (i.e., 0, 1, 2, 3, etc. occurrences) events such as queues. Using this statistical technique we see that building queue storage to fit the average means you will “fail” 30% to 40% of the time.

### QUEUE STORAGE

#### Designing Left Turn Storage for Success

**Remember:**  
you need almost twice  
the average queue  
for storage length

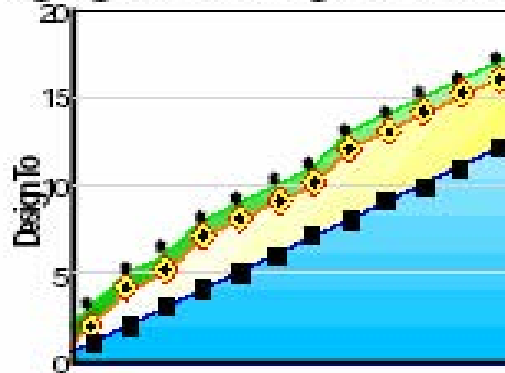

Average Demand Per Cycle	1	2	3	4	5	6	7	8	9	10	11	12
30-40% Failure	1	2	3	4	5	6	7	8	9	10	11	12
10% Failure	2	4	5	7	8	9	10	12	13	14	15	16
5% Failure	3	5	6	8	9	10	11	13	14	15	16	17

Source: Use of Poisson Approximation

You should recognize that application of the Poisson Distribution to queue storage length problems assumes that all vehicles arriving on a cycle (or in a specified interval) clear the intersection on that interval. The Poisson Distribution should not be used where one or more vehicles do not clear the intersection and must wait for the next interval. Queue storage where such “carry over” from one cycle to another involves much more complicated analyses. Using Poisson Distribution you can determine the queue length necessary to have “success” 90% of the cycles (usual standard).



**Rule of Thumb:**

***Design queues are usually 1.5 to 2 times the average.***

The following table contains the recommended queue storage length of as variety of left turn volumes. The recommendations were based on a 90% success rate for non-SIS/FIHS facilities and 95% for the FIHS. You must consider the historic variability of these numbers, as well as the inherent inaccuracies of traffic projection models when making your recommendation. When possible and desirable get more storage where projections seem to be “light”.

Recommended Queue Storage for Unsignalized Median Openings		
Lefts per Hour	Recommended Queue (non SIS/FIHS)	Recommended Queue ( SIS/FIHS)
30	2 (only in small towns or rural areas)	3 (only in small towns or rural areas)
40	3 (only in small towns or rural areas)	4
50	3	4
60	4	5
70	4	5
80	5	6
90	5	6
100	6	7
110	6	7
120	7	8
130	7	8
140	7	8
150	8	9



**Assumptions:** 120 second interval, Approximate probability of success is 90% non-FIHS and 95% SIS/FIHS

**Queue Length  
Adjustments for Trucks**

The length of 25 feet is an average distance, front bumper-to bumper of a queue. If the queue is comprised mostly of passenger cars, this distance provides for an average distance between vehicles of about one-half car length.

If 5% or more large vehicles are expected, the average queue length, including gap, per vehicle should be increased as follows:

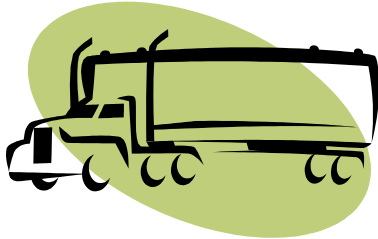

**ADJUSTMENT FOR LARGE VEHICLES**

Percent Trucks	Average Storage Length per Vehicle
5%	27 ft
10%	29 ft
15%	32 ft
20%	35 ft

Source: Adapted from Transportation and Land Development, Stover and Koepke

**Use Caution Near Railroad Crossings**



Use caution to assure that queues will not be placed over downstream railroad crossings. Railroad crossings should not be anywhere near the functional area on an intersection.

*For more information on Queues, Storage, and Projecting Left Turns:*

- AASHTO Green Book
- FDOT Project Traffic Forecasting Handbook, Statistics Office,
- Volume Warrants for Left-Turn Storage Lanes at Unsignalized Grade Intersections, M.D. Harmelink
- For Signalized Intersections: Storage Requirements for Signalized Intersections Approaches, Joseph and Jane Oppenlander, ITE Journal, Feb. 1996

**Median Opening Spacing — How All These Factors Impact the Spacing of Openings**

The spacing of median openings will be the sum of the following factors for both directions of the roadway.

- Deceleration
- Queue Storage
- Turn Radius (usually 60 feet)
- Perception/Reaction distance or Full Width of Median - The length of the median which is not a part of the turn lanes or the taper. These sections provide for visibility, buffer and landscaping opportunity.

**Design Speed – 45 mph  
Suburban Location**

Left Turn Queue Storage (Signalized) = 350 ft  
Deceleration = 185 ft

Left Turn Queue Storage (Unsignalized) = 100 ft  
Full width median = 130 ft  
Turn Radii = 60 ft

**A REALISTIC MINIMUM URBAN SCENARIO *Example***

Urban conditions @ 45 mph design

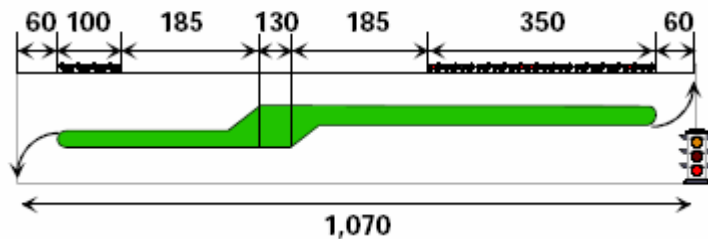

**WHY IS 1/2 MILE SPACING SO GOOD?**

Space for:

- Safety
- Operations
- Flexibility
- Signal Progression
- Aesthetics

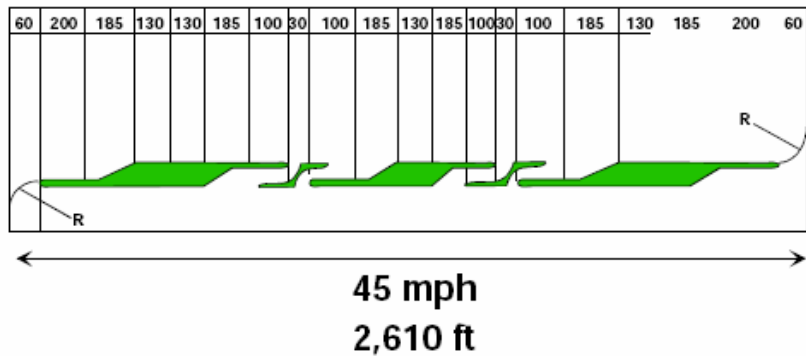

## 2.4

### WHAT DISTANCE IS NEEDED FROM A FREEWAY RAMP TERMINAL TO THE FIRST MEDIAN OPENING?

Observations indicate that drivers tend to make erratic maneuvers when there is a limited separation between the gore area of the off-ramp and the median opening, drivers will make erratic maneuvers as illustrated. Desirable conditions would permit a driver to accelerate, merge into the outside traffic lane, select an acceptable gap in order to merge into the inside lane and then move laterally into the left-turn lane and then come to a stop as illustrated.

#### SPACE NEEDED BETWEEN FREEWAY OFF-RAMP AND MEDIAN

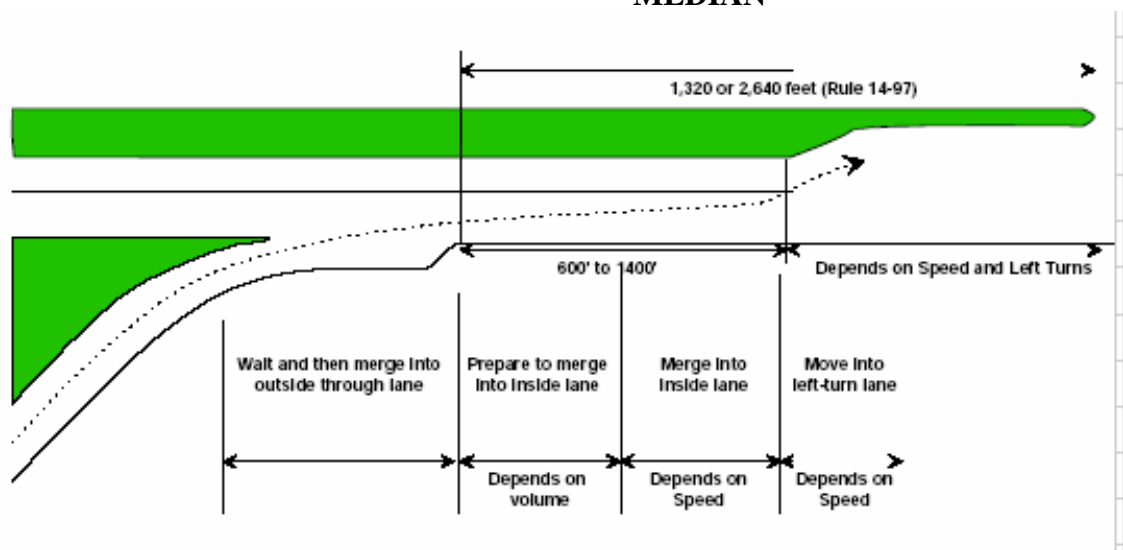

We already have sufficient guidance on the distance needed for queues and deceleration. Determining the appropriate distance for the weaving portion of this maneuver may be accomplished through a technique developed by Jack Leisch in *Procedure for Analysis and Design of Weaving Sections* (FHWA Project - 1982). The procedure was developed to determine weaving distances from freeway ramps to intersections on frontage roads. This technique as adapted by Joel Leisch, is transferable to the analysis of weaving on to an arterial road.

This weaving distance may be determined by.

- conflicting weaving vehicle flows
- desired running speed of the weaving vehicles

The next figure shows how conflicting movements are determined.



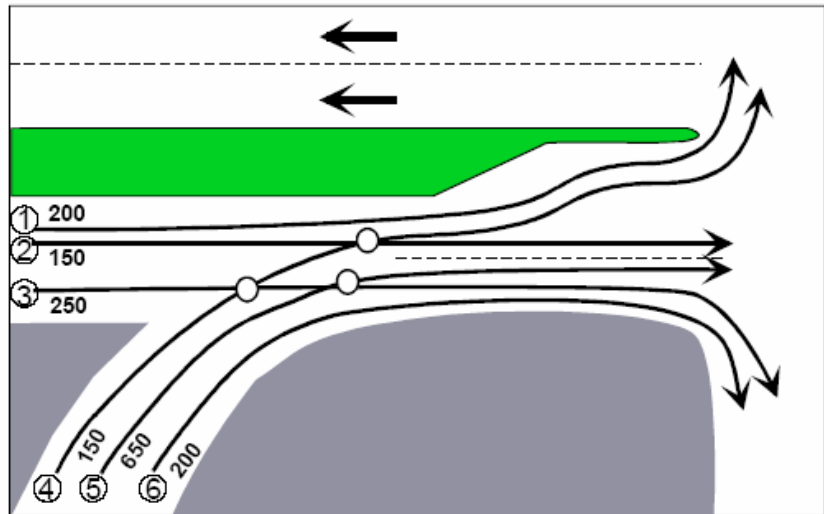

The total volumes for conflicting **crossing** (not simply weaving) streams are as follows:

<b>Movement</b>	<b>Volume</b>
2	150
3	250
4	150
5	650
<b>Total</b>	<b>1,200</b>

If you wanted to design for a weaving speed of 35 mph you would use the following graph going up the left side to 1,200 and then going to the right until you get to the 35 mph line. Then you would follow the line down to the bottom of the graph to read approximately 600 feet. Experience shows that most urban situations fall within 800 to 1,600 conflicting weaving movements in the peak hour. If we design for a weaving running speed between 35 and 45 mph, we see that the weave section should be between 400 to 1,600 feet.

*Experience shows that most urban situations fall within 800 to 1,600 conflicting weaving movements in the peak hour. If we design for a weaving running speed between 35 and 45 mph, we see that the weave section should be between 400 to 1,600 feet.*

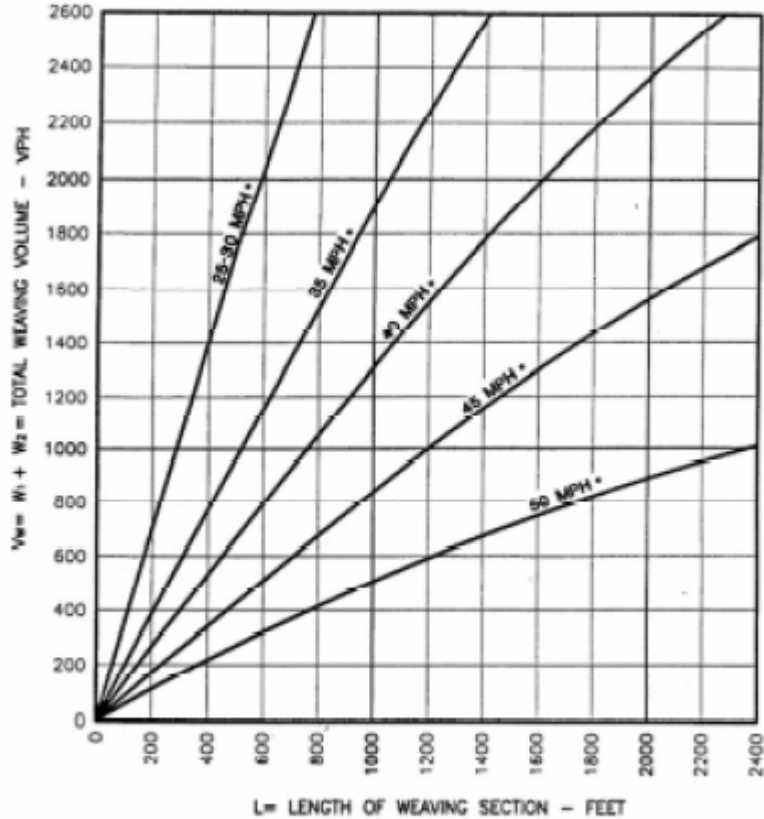

**IMPORTANT POINT** 

These measures is strictly the minimum weaving and maneuver distance from the end of the ramp to the beginning of the deceleration area of the interchange not to the median opening or traffic signal.

This technique is most useful in unsignalized off ramp situations. If the ramp is signalized, this weaving distance will need to be determined by a signal spacing analysis.

## 2.5

### MEDIAN END TREATMENTS

The median end design for an urban arterial should be designed for a passenger vehicle while assuring it can accommodate a larger design vehicle. Different median ends can be used. Alternative designs are semicircular, symmetrical bullet nose, asymmetrical bullet nose, half-bullet nose, **but remember: always use turn lanes.**

---

*The only new openings that will be provided without turn lanes would be for official or emergency use only.*

---



---

#### Problem

---

#### A Strictly Bullet Nose Opening

The “bullet nose” median opening requires a vehicle to make a left turn from a through traffic lane (see next figure) interfering with the through traffic. This will result in a situation with a high potential for rear-end crashes.

#### POTENTIAL CRASH PROBLEMS WHEN LEFT-TURN IS MADE FROM THE THROUGH TRAFFIC LANE

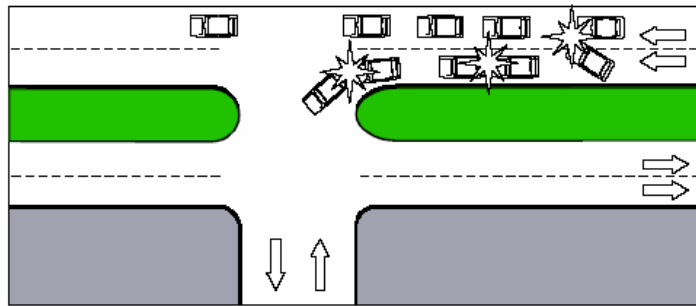



---

#### Solution

---

The only way in which left-turn vehicles can be removed from a through traffic lane is to install a left-turn bay (see next Figure). The lane should be of sufficient length to allow for adequate maneuver distance plus queue storage as discussed in Chapter 2. The total length of the left-turn deceleration lane, including the taper, should be sufficient to allow the turning vehicle to decelerate from the speed of through traffic to a stop plus queue storage. Existing bullet nose, median openings should be replaced with a left-turn lane.

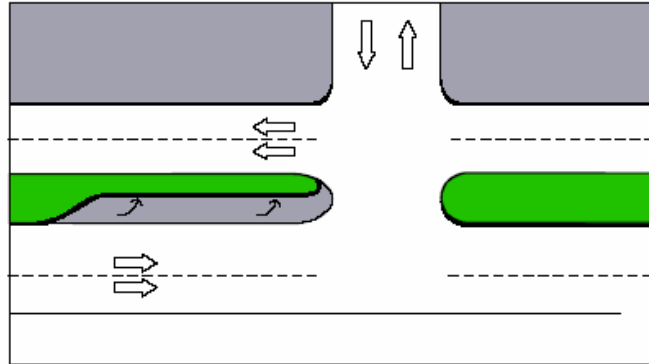
**LEFT-TURN LANE TO REMOVE LEFT-TURN VEHICLES FROM THE THROUGH TRAFFIC LANES**



**2.5**

**MEDIAN OPENING LEFT TURN RADIUS**

The Department has historically used 60 ft for most situations and 75ft when significant truck volumes are expected.

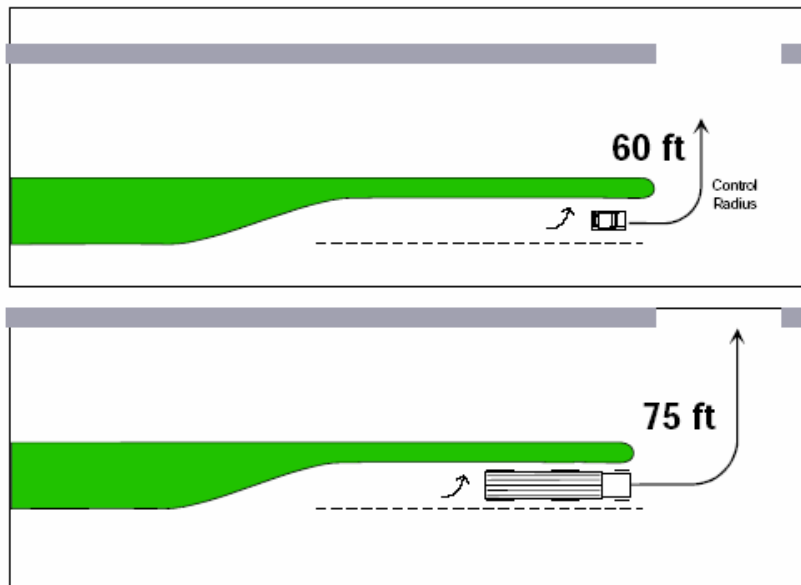

## 2.6

### MEDIAN OPENING LENGTH

---

*Problem:*

---

Median opening length is governed by the

- Turn radii
- Side street geometrics
- Median (traffic separator) width
- Intersection skews
- Intersection legs

#### Excessively Wide Median Opening

An excessively wide median opening will store two or more vehicles in an unsignalized full median opening while they are waiting to complete a maneuver results in multiple conflicts for both the turning vehicles and through traffic. The situation shown results at full median openings on high volume roads during peak periods. This often occurs in areas where development has occurred and traffic volumes substantially increased since the median opening was originally constructed.

#### VEHICLES STOPPED IN EXCESSIVELY WIDE MEDIAN OPENING

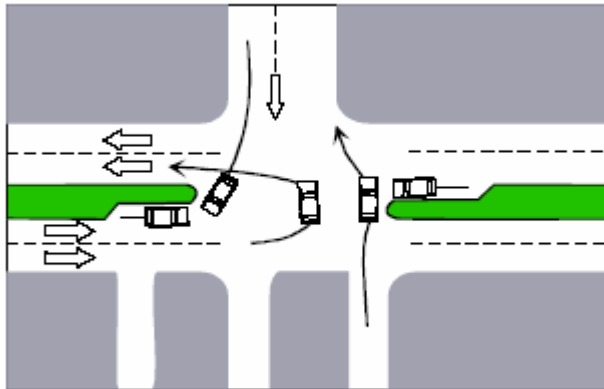

---

*Solutions:*

---

Alternative solutions to the problem are:

- 1) Reconstruct the unsignalized full opening as a more restrictive median opening.
- 2) Close the median opening.

Which solution is selected, as well as the design of the restrictive movement if used, will depend upon such things as proximity to other median openings, alternative routes, traffic volumes and crash experience.

The presence of several vehicles in the median opening results in impaired sight distance, especially when one or more of the vehicles is a pickup, van, or RV. Signalization should be considered only if the median opening otherwise conforms to signalized intersection standards.

*For More information on Median Opening Length:*

- AASHTO Green Book Median Openings Section of "At-Grade Intersections"

## 2.7

### PAVEMENT MARKINGS AND SIGNING

The Manual on Uniform Traffic Devices (MUTCD) contains guidance on the type and placement of signs and traffic control devices at median opening areas.

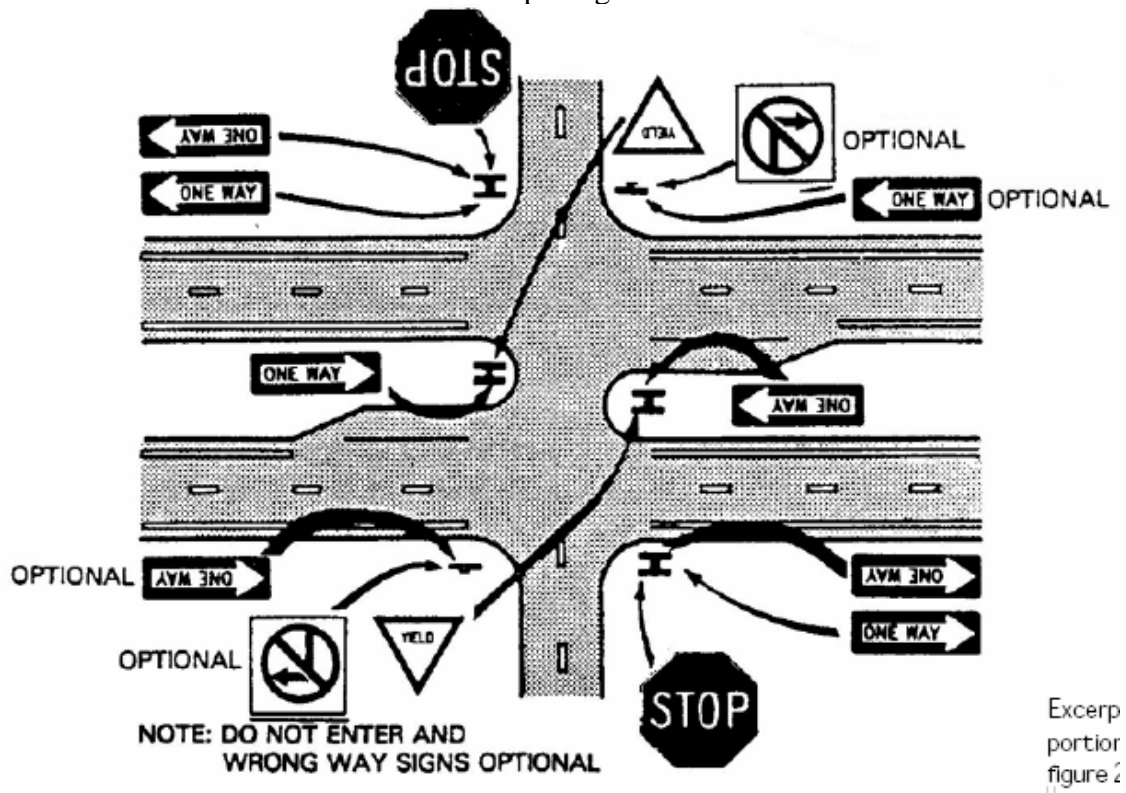

*Excerpt from the lower portion of M.U.T.C.D. figure 2-3a*

*This is an example for signing on extra wide medians in rural areas.*

**3**

**Sight Distance**



**Source:** Florida Highway Landscape Guide - 1995  
**SIGHT DISTANCE AS IT RELATES TO MEDIANS AND  
 MEDIAN OPENING DESIGN**

**3.1**

---

**INTRODUCTION TO  
 SIGHT DISTANCE  
 CONCEPTS**

This chapter addresses sight distance issues related to unsignalized median openings and roadway connections. The bulk of the chapter contains discussion of the assumptions relating to stopping and intersection sight distances. We use AASHTO Green Book as a basis for much of the Florida standards. Right turn and passing sight distance is not addressed because they are not normally an element in median opening location and design.

Highways must be designed to provide sufficient sight distance so that drivers can control and safely operate their vehicles. The following sight distances are of concern on median and median opening decisions, both urban and rural.

- **Stopping Sight Distance:** The distance necessary for the driver to safely bring a vehicle to a stop.
- **Intersection Sight Distance:** The distance necessary for drivers to safely approach and pass through an intersection.



- **Height of Eye** - In determining sight distance, the height of the eye of the person who must stop or pass through the intersection is assumed to be a certain measure. This assumption has significant bearing on such issues as the placement of landscaping which might obstruct the view of the vehicle at the assumed height.
- **Height of Object** - AASHTO assumes a determined height of object for intersection sight distance. This will allow the driver to view the headlights of an oncoming passenger car.

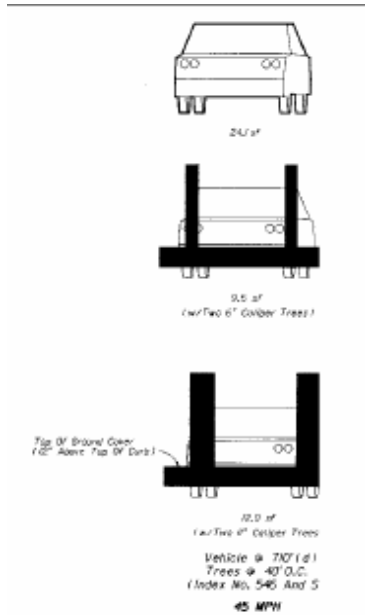

### AREA SIZE OF VEHICLE

Florida DOT has developed criteria for sight distance that allows a 50% “Shadow” control for sight DISTANCE. This means that if a driver can see at least 50% of the visual area of a vehicle it is considered “visible”.

### TIME OF VISIBILITY

Where visibility is blocked by over 50%, the Department will allow for two seconds unobstructed visibility.

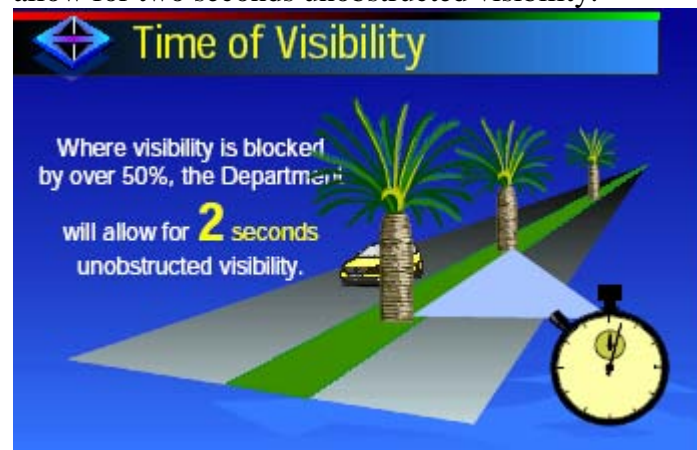

### WHAT IS STOPPING SIGHT DISTANCE?

Sight distance is the length of roadway ahead visible to the driver. The minimum sight distance available on a roadway should be sufficiently long to enable a vehicle traveling at or near the design speed to stop before reaching a stationary object in its path. The sight distance at every point along the highway should be at least that required for a below-average operator or vehicle to stop in this distance.



**Minimum Stopping Sight Distance**

<b>Minimum Stopping Sight Distance (Feet)</b> For application of stopping sight distance, use an eye height of 3.5 feet and an object height of 0.5 feet above the road surface	
<b>Design Speed</b>	<b>Minimum Stopping Sight Distance (feet)</b>
35	250
45	360
55	495
60	570
65	645
<b>Source:</b> Plans Preparation Manual Vol. I Table 2.7.1	

**3.2**

**SIGHT DISTANCE FOR SPECIFIC MEDIAN OPENING MANEUVERS**

3.2.1 Right Turns and Left Turns on Divided Roadway

Design Standard Index #546 specifies the following sight distances for right and left turns at intersections on multi-lane roads with medians. These should be considered minimums. The following figure shows an example at 45 mph with a 22 ft median width.

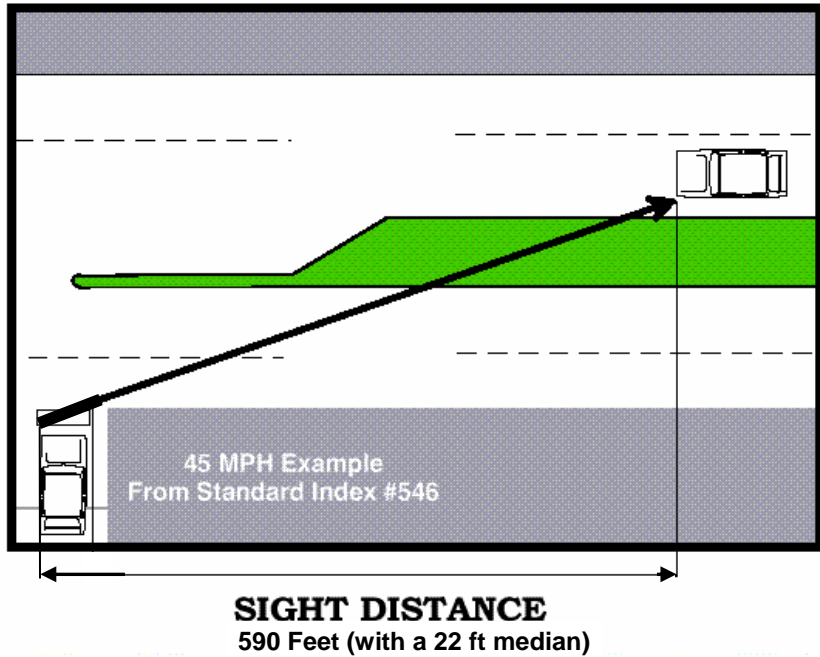

<b>Intersection Sight Distance by Design Speed</b>		
<b>Design Speed (mph)</b>	<b>Intersection Sight Distance (Feet)</b>	
	<b>22 ft Median</b>	<b>25 to 64 ft median*</b>
35	460	330
45	590	430
55	720	530
60	780	570

- If the median width is over 25 feet, than the passenger car (P) can make the maneuver as a two-step process

**Source:** Design Standard Index 546

### Turning left through a Median as a Two-Step Maneuver

For divided highways with medians (the median is wider than the length of the design vehicle plus front and rear clearance), the maneuvers can be performed as two operations. The stopped vehicle must first have adequate sight distance to depart from a stopped position and cross traffic approaching from the left. The crossing vehicle may then stop in the median prior to performing the second operation. The second move requires the necessary sight distance for vehicles to depart from the median, to turn left into the cross road, and to accelerate without being overtaken by vehicles approaching from the right.

## Sight Distance for U-Turns

U-Turns are more complicated than simple turning or crossing maneuvers. Knowing this, sight distances for U-Turns were calculated for automobiles with the following assumptions:

- “P” vehicle (Passenger vehicle)
- 2.0 seconds reaction time
- Extra time spent in the u-turn maneuver
- Begin acceleration from 0 mph only at the end of the U-Turn Movement (this is conservative)
- Use of speed/distance/and acceleration figures from AASHTO Green Book 1990, Figures IX-34 pg. 749
- 50 feet clearance factor

Sight Distance for U-Turn at Unsignalized Median Opening	
Speed MPH	Sight Distance (ft.)
35	520
40	640
45	830
50	1,040
55	1,250
60	1,540
SI/METRIC	
Speed	Sight Distance(M)
60km/h	160 M
70km/h	200 M
80km/h	260 M
90km/h	380 M
100km/h	470 M

### HOW A U-TURN SIGHT DISTANCE WAS CALCULATED

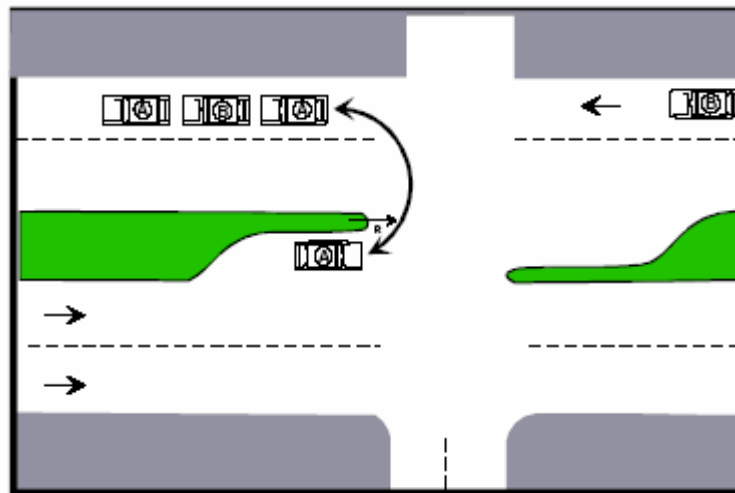

## Sight Distance for Left Turn into Side Street

In most cases the right turn sight distance from the side street would control the sight distance of this area. If the area has enough sight distance to allow a right turn vehicle from the side street, the sight distance should have sufficient sight distance for the vehicle turning left from the median into the side street.

## Left Turn Lane Offset

Vehicles turning left from opposing left turn lanes restrict each other's sight distance unless the lanes are sufficiently offset. Offset is defined as the lateral distance between the left edge of a left turn lane and the right edge of the opposing left turn. When the right edge of the opposing left turn is to the left of the left edge of the left turn lane, the offset is negative as shown. If it is to the right, it is a positive offset as indicated below.

**From Plans Preparation Manual**

Desirable offsets should all be positive with a recommended minimum 2-foot offset when the opposing left turn vehicle is a passenger car and a recommended minimum 4-foot offset when the opposing left turn vehicle is a truck. In both cases the left turn vehicle is assumed to be a passenger car.

On all urban designs offset left-turn lanes should be used with median widths greater than 18 feet. A four foot traffic separator should be used when possible to channelize the left turn and provide separation from opposing traffic. On rural intersections where high turning movements are involved, offset left-turn lanes should also be considered.

On median widths 30 feet or less, an offset turn lane parallel to the through lane should be used and the area between the left turn and traffic lane where vehicles are moving in the same direction should be striped out. On medians greater than 30 feet, a tapered offset should be considered.

**Source:** Plans Preparation Manual Vol. I, 2.13.1

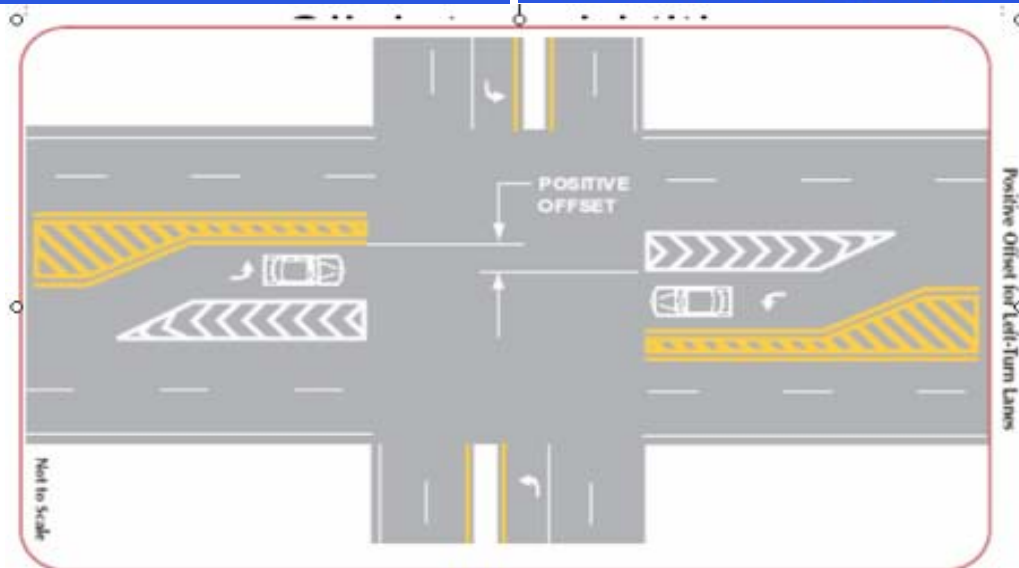
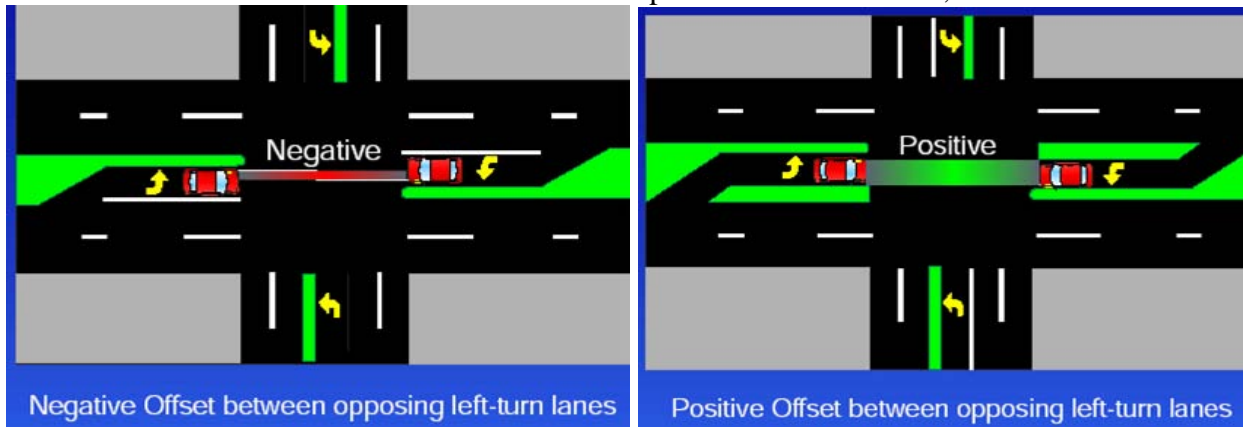



*For More Information on Offset:*

- District 1 Access Management Unsignalized Median Opening Guidelines
- Transportation Research Record #1356

### 3.3

## LANDSCAPING AND SIGHT DISTANCE ISSUES

*When the number of median openings and driveway connections are reduced, a greater area is generally available for landscaping.*

Two important Florida Department of Transportation documents address landscaping as they relate to medians:

- Standard Index #546 (Sight Distance)
- “Florida Highway Landscaping Guide” (FDOT, Environmental Management Office)

The **Landscape Guide** States the Importance of Access Management in Providing Good Visibility and Landscaping Opportunities:

*“Access management is the management of vehicular access to the highway. This includes ingress to the highway, egress from the highway and median openings on divided highways. A well-designed highway with good access management can be aesthetically pleasing. It provides the landscape architect greater opportunity in the development of practical and efficient landscape plans. When the number of median openings and driveway connections are reduced, a greater area is generally available for landscaping. The reduction of median openings and driveways also reduces the number of locations that must meet clear sight requirements. This allows greater flexibility in the landscape plan. Therefore, any plan for landscaping a highway should consider access management.”*

### Major Criteria for Decisions on Sight Distance and Planting Area and Spacing in Medians

- **Sight Distance** - for left turns as stated in Standard Index #546
- **Stopping Sight Distance** (for absolute clear area)
- **Tree Caliper** – 4 – 11 in. and greater than 11 in. to 18 in.
- **Tree Spacing** - as stated in Standard Index #546
- **Area Size of Vehicle Seen** - 50% coverage or 2 seconds of complete visibility
- **Horizontal Clearance** - as stated in Standard Index #700 or Plans Preparations Manual
- **Clear sight window** criteria - see next Figure.

Why are the same standards used for both signalized and unsignalized intersections?

- Signal can malfunction
- Signal can go to flashing mode

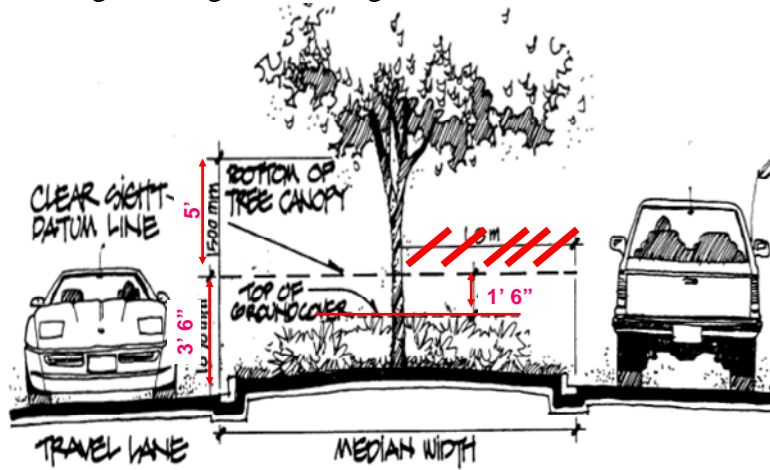

## CLEAR SIGHT WINDOW

[median landscape sight window.ppt](#)

Source: Adapted from the Florida Highway Landscape Guide, Environmental Management Office, 1995

## Tree Spacing Guidance – Standard Index 546

Description	Speed (mph)													
	30	35	40	45	50	55	60	30	35	40	45	50	55	60
	(Inches)													
Diameter (Within Limits Of Sight Window)	>4≤11	>11≤18	>4≤11	>11≤18	>4≤11	>11≤18	>4≤11	>11≤18	>4≤11	>11≤18	>4≤11	>11≤18	>4≤11	>11≤18
	(Feet)													
Minimum Spacing (c. to c. Of Trunk)	22	91	27	108	33	126	40	146	45	165	52	173	60	193
<p>Sizes and spacings are based on the following conditions:</p> <p>(a) A single line of trees in the median parallel to but not necessarily colinear with the centerline,</p> <p>(b) A straight approaching mainline, within skew limits as described in No. 2 above.</p> <p>(c) 1. Trees and palms ≤11" in diameter casting a vertical 6' wide shadow band on a vehicle entering at stop bar location when viewed by mainline driver beginning at distance 'd'; see SHADOW DIAGRAM, Sheet 6.</p> <p>2. Sabal palms with diameters &gt;11" to ≤18" spaced at intervals providing a 2 second full view of entering vehicle at stop bar location when viewed by mainline driver beginning at distance 'd'; see PERCEPTION DIAGRAM, Sheet 6.</p> <p>(d) Trees with diameters ≤11" intermixed with trees with diameters &gt;11" ≤18" are to be spaced based on trees with diameters &gt;11" ≤18".</p>														

The spacing of trees is based on the design speed and the caliper of the tree trunk. Once the caliper of the tree trunk is over 18", the driver can completely lose sight of the other vehicle, therefore, the spacing of the trees increases dramatically to allow a complete 2 second view between trees.

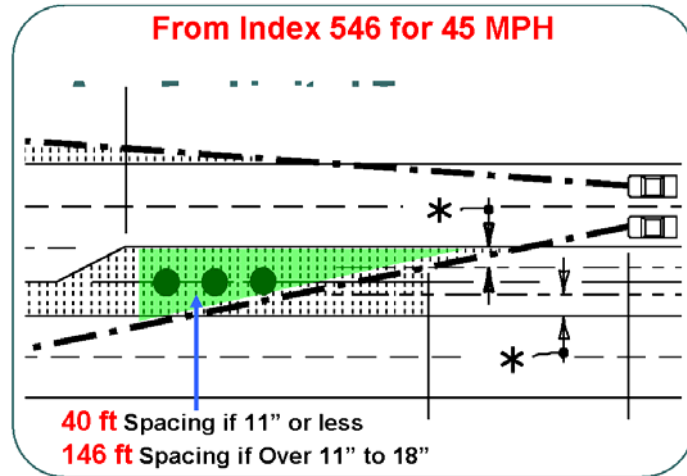

96

### Areas Limited to Ground Cover

Standard Index 546 also has important direction on areas that should never have any landscaping except low groundcover. At a minimum, it should be stopping sight distance or to the start of the turn lane taper (whichever is the longest measure)

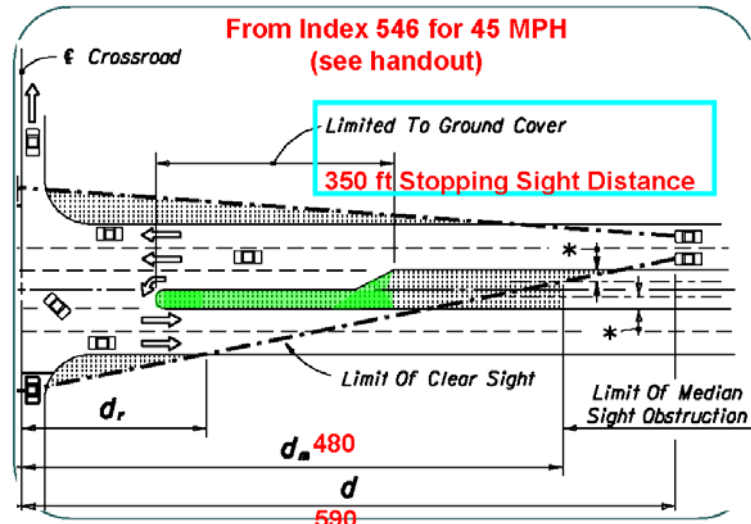

95



## Trees In Median Intersection Sight Corridor And Outside Clear Zone (6' Horizontal Clearance), Curb And Gutter

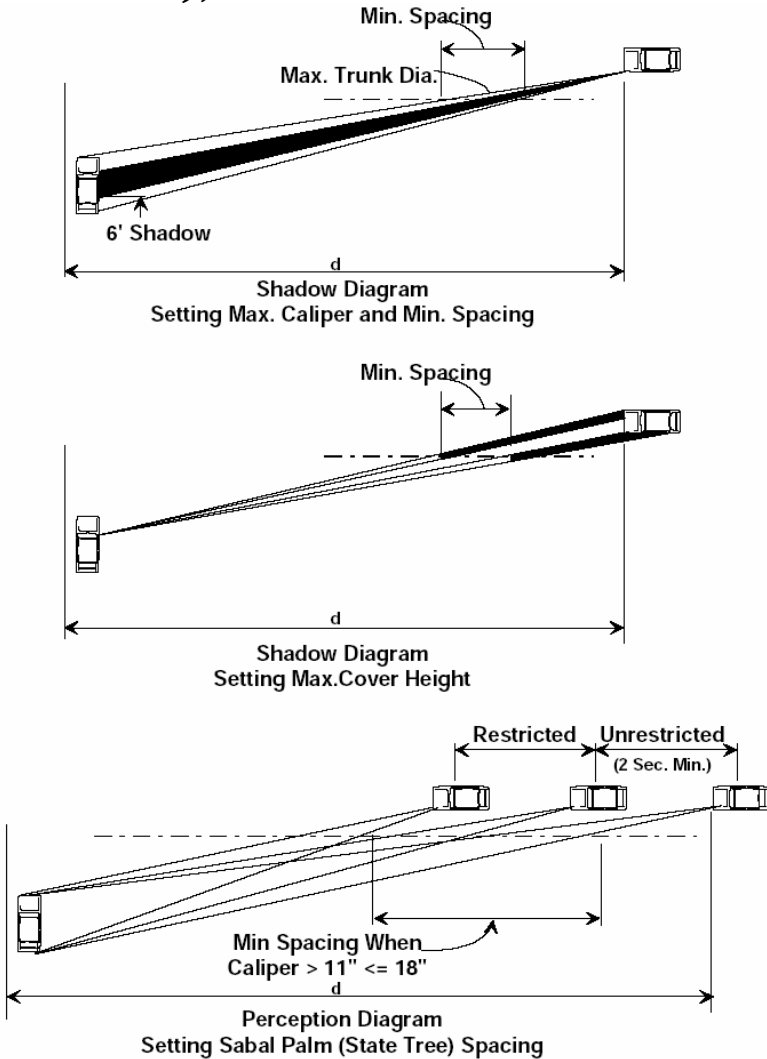

*For More Information on Landscaping and Sight Distance:*

- Florida Highway Landscaping Guide, FDOT - Environmental Management Office (1995)
- AASHTO Green Book (1990), pg. 739
- Standard Index #546 (Sight Distance at Intersections)



4

Median Width



**MEDIAN WIDTH**

4.1

**Function Determines Median Width**

The appropriate median width is a function of the purpose which the median is to serve in a particular application. Applications on roadways having at-grade intersections which affect median width include the following:

- Separate opposing traffic streams
- Pedestrian refuge
- Left-turn to side street
- Left-turn out of side street
- Crossing vehicles
- U-turns
- Aesthetics and maintenance

## 4.2

### ANATOMY OF MEDIAN WIDTH

*Important Point:  
Never use the gutter  
space as part of  
your turn lane  
width.*

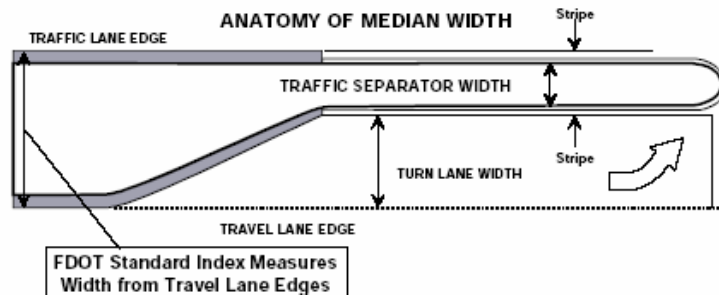

Median width in most urban situations is made to accommodate turning lanes and a separator. The width of both the lane and separator are critical to the operations of the median opening.

## 4.3

### Minimum and Recommended Widths

#### SUMMARY OF STANDARDS AND RECOMMENDATIONS

Guidance	Design Speed and Notes	Width (Feet)
Minimum	<i>Plans Preparation Manual</i> (Reconstruction Projects) = 40 mph and less	15.5
Minimum	<i>Plans Preparation Manual</i> (Reconstruction Projects) 45 mph	19.5
Minimum	<i>Plans Preparation Manual</i> (less than 55 mph)	22
Guidance from Plans Preparation Manual	When greater than 55 mph	40
Recommended	4 lane highways with medians expecting significant u-turns and directional median openings with excellent positive guidance	30 for single left turns 42 for dual lefts
Recommended	6 lane highways with medians expecting significant u-turn and directional median openings with excellent positive guidance	22 for single left turns 34 for dual lefts

Where left turns are not expected due to terrain or land use, a median as narrow as 6 feet can help channelize traffic and provide more positive guidance and prevent unwanted left turns. A critical function of many medians is to protect vehicles turning left. The following figure shows how some narrow medians cannot do this task.

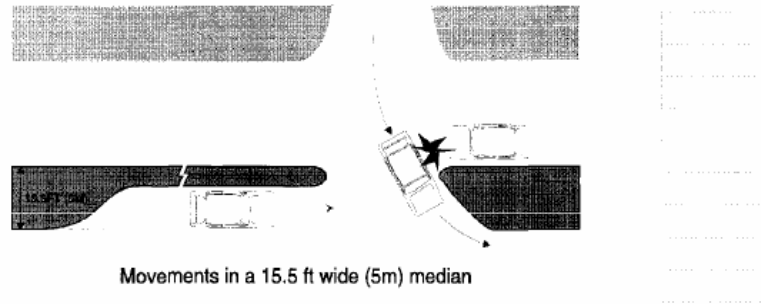

## 4.4

### SOME EXAMPLES

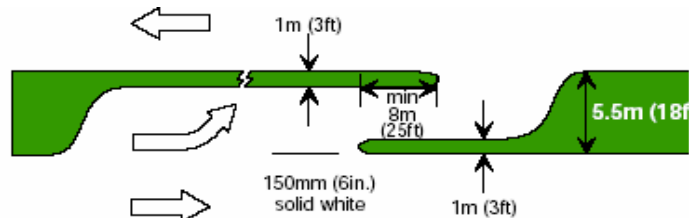

**Minimum Design for Restrictive Left-Turn Ingress**

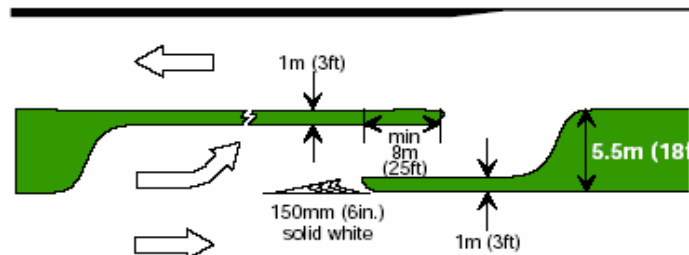

**Desirable Design for Restrictive Left-Turn Ingress**

Median Width: 9m (30 ft) -  
What it does

#### DESIRABLE ASPECTS

- Greater flexibility in the choice of lane widths and separation width at double left-turn, full median openings.
- Additional width for landscaping the overlapping “traffic separators” at directional median openings.
- Permits separate vertical and/or horizontal alignment of the two roadways.

*For more information on Turn Lane Width:*

- Plans Preparation Manual Table 2.1.1

## 4.5

### MINIMUM TRAFFIC SEPARATOR WIDTH AT INTERSECTIONS

The minimum width of a median traffic separator "nose" has commonly been 4 ft. Where the right-of-way is limited, 2 ft and even as little as 18 in. has been used. AASHTO indicates that "... *the minimum narrow median width of 4 ft is recommended and is preferably 6 to 8 ft wide.*" (AASHTO Green Book). The 1994 edition included the same statement with 1.2m minimum and preferable widths of 1.8 to 2.4m (p. 786).

## 4.6

### PEDESTRIAN CONSIDERATIONS AT TRAFFIC SEPARATORS

Pedestrian refuge minimum for common practice is to use a minimum of a 4 ft separator between the left-turn lane and the opposing traffic lane. The minimum width for pedestrian refuge is 6 ft. Where more than occasional pedestrians may be present, the median width should be at least 8.5 ft and preferable at least 10 ft.

## 4.7

### SEEING TRAFFIC SEPARATORS AT INTERSECTIONS

Very narrow median noses are very difficult to see, especially at night and in inclement weather. Reflectorized paint is of little help as it rapidly becomes dirty and loses its limited reflectivity. Reflectorized traffic buttons and/or reflectorized pylons help but lack the "bulk" to provide good "target value". Carefully selected landscaping is the only effective way to provide excellent visibility of the median and median openings. A minimum traffic separator width of 6 ft and preferable 8.5 ft. is needed for the median nose to be of sufficient width back-to-back of curbs to provide adequate area for vegetation to make it highly visible. Landscaping of the median nose to provide visibility is especially important where long left-turn lanes are used. Obviously the choice of vegetation and the landscaping design must ensure that sight distance is not obstructed.

## 4.8

### MINIMUM MEDIAN WIDTH FOR U-TURNS

SEE CHAPTER 5 FOR COMPLETE ANALYSIS

U-turns should not be permitted from through traffic lane because of the potential for high speed, rear-end crashes and serious detrimental impact on traffic operations. Rather all left-turns, and u-turns should be made from a left-turn/u-turn lane.

Extremely wide medians are needed for a u-turn by all design vehicles other than the P-vehicle, the P-vehicle can not make a u-

turn on a 4-lane divided roadway with curb and gutter and commonly used median nose widths. A very high percentage of the automobile fleet is intermediate and smaller than the "P" design vehicle. Small or intermediate vehicles can complete a u-turn on a 4-lane divided roadway having curbs and gutters and a 2m (6 ft) median traffic separator nose.

The design P-vehicle can make a u-turn on a 4-lane divided roadway with a 6 ft. median nose by "flaring" the receiving roadway.

## 4.9

### DESIGN FOR TRUCKS

See chapter 5 for a more complete discussion of truck U-turns

The extremely wide median that is required for buses and trucks to make a u-turn makes it impractical to design for these vehicles except in exceptional cases. The need for u-turns by large vehicles can generally be avoided in the following ways:

- (1) Bus routes can be laid out so as to eliminate the need for u-turns on a major roadway.
- (2) Driveway connections can be located and on-site circulation designed to eliminate the need for u-turns by trucks.





**Special U-Turn Considerations**

**5**

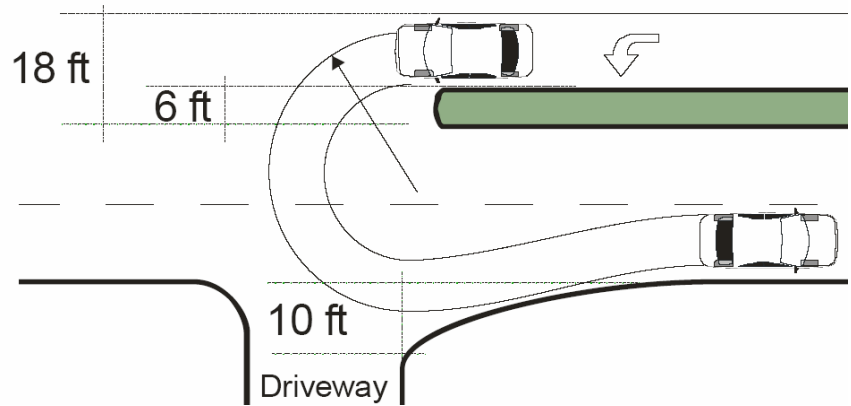

**SPECIAL U-TURN CONSIDERATIONS**

**5.1**

**AASHTO GUIDANCE ON WIDTH AND U-TURNS**

The AASHTO GREEN BOOK contains some guidance on the relation between median width and u-turn movements. Unfortunately, the figure in the Green Book shows the u-turn movements made from the inside (left) lane. This is contrary to the basic principle of having left turns made in auxiliary lanes rather than through lanes. Therefore, you need to add at least 12 feet to the width for this purpose. The next figure shows the AASHTO Green Book figures with 12 feet added for a better guide to median width and u-turns. As you can see, in order to make the width sufficient for a Passenger Car (P) to make a u-turn from the turn lane to the outer lane, it would require 30 feet. If you cannot provide 30 feet, then the car will encroach on to the shoulder. This is okay as long as this encroachment has been built into the design. When designing for 6 lane highways, 20 feet of median width will usually provide sufficient space for the u-turn for the passenger car (P) vehicle.

**IMPORTANT:** The “P” vehicle is approximately the size of a luxury car or a Chevy Suburban. Therefore, many vehicles in today’s passenger car fleet can make tighter u-turns.

### Minimum Width of Median for “U” Turn on 4 Lane Road

Measures in feet	Passenger P	Single Unit SU	Semi Trailer WB-50
 Turn Lane to Inner Lane	<b>42</b>	<b>75</b>	<b>83</b>
 Turn Lane to Outer Lane	<b>30</b>	<b>63</b>	<b>71</b>
 Turn Lane to Shoulder	<b>20</b>	<b>53</b>	<b>61</b>

Source: adapted from AASTO Green Book (with added 12 ft for turn lane width)

## 5.2

### OPTIONS FOR U-TURNS

In order to handle u-turns there are essentially three options available:

1. Wide medians

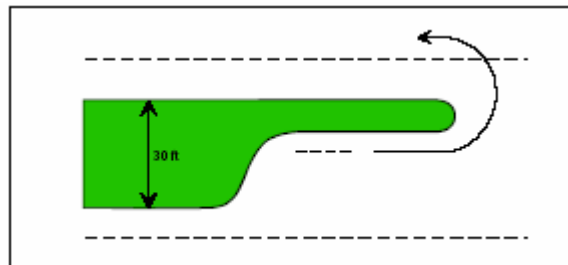

2. Median “Bulb-Out”

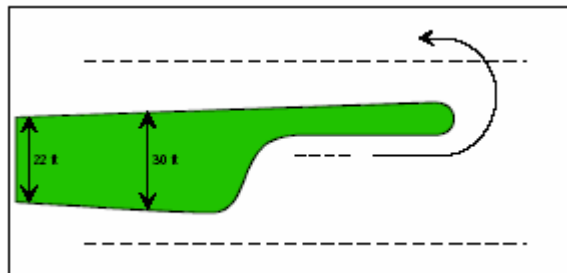

### 3. Flare-Out (Jug Handles)

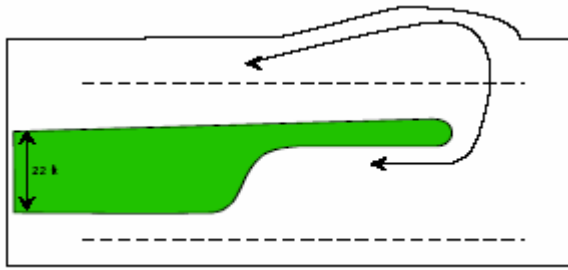

Each of these options has their strengths and weaknesses. Traffic, land use and terrains will play important roles in the decision on their options.

#### Two Examples of a Flare

The design P-vehicle can make a u-turn on a 4-lane divided roadway with a 6 ft. Traffic separator by “flaring” the receiving roadway or where a far-side bus stop is used, the u-turn can be accommodated as illustrated in the following Exhibits.

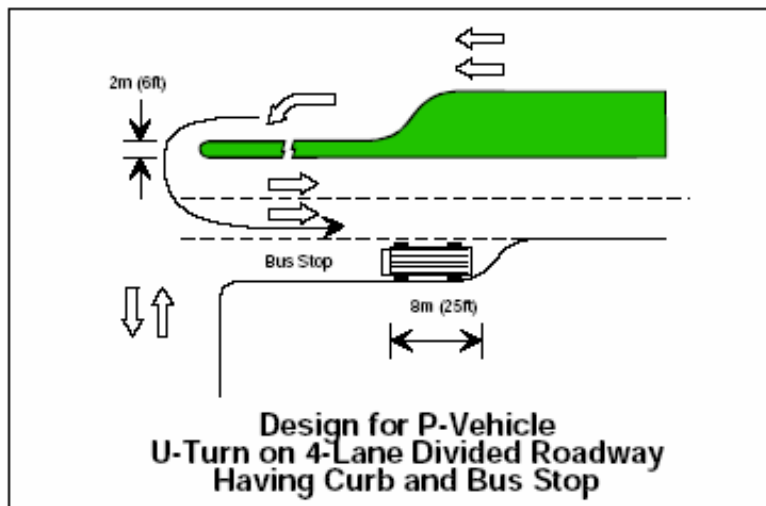
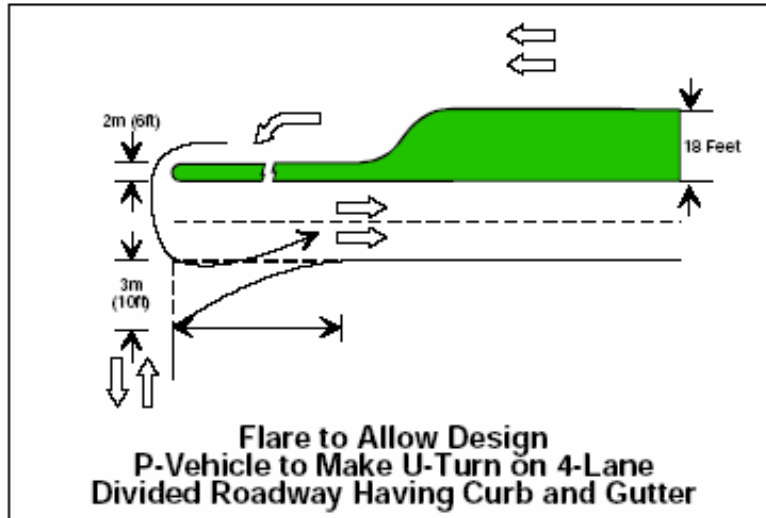

## 5.3

### TRUCK U-TURNS

*These special designs will probably only be necessary at, or near, truck facilities, major industrial areas, or truck staging areas.*

Alternatives for accommodating u-turns by large vehicles (such as delivery, trucks and semis)

Special consideration for truck u-turns is usually not a major consideration.

The extremely wide median that is required for buses and trucks to make a u-turn makes it impractical to design for these vehicles except in exceptional cases. The need for u-turns by large vehicles can generally be avoided in the following ways:

- Bus routes can be laid out so as to eliminate the need for u-turns on a major roadway.
- Driveways can be located and on-site circulation designed to eliminate the need for u-turns by trucks.
- Local governments can avoid the need for u-turns by large vehicles through their subdivision, and site development ordinances.

#### U-TURN DESIGNS FOR LARGE VEHICLES

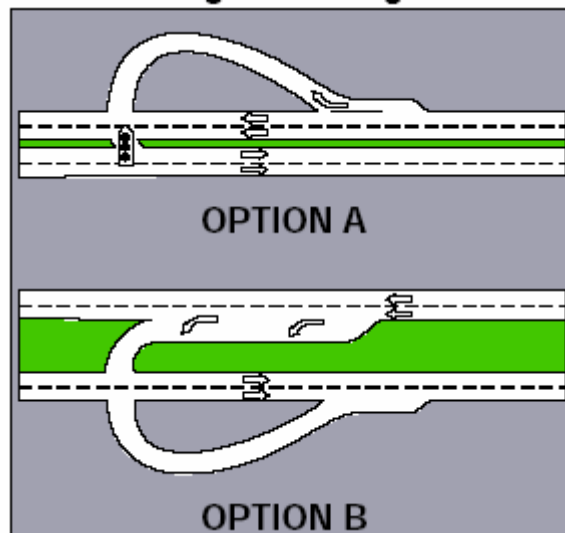

In most cases Option "A" would need a signal. Option "B" has the following desirable operational features.

- The u-turning vehicle is stored in the median parallel to the through traffic lanes.
- A suitable gap is needed in the opposing traffic stream only.
- After completion of the u-turn the driver can accelerate prior to merging into the through traffic lane.

These options require more right-of-way than most standard highway designs, but it may be designed into our highway corridors where public land is available such as parks, government maintenance facilities, etc. These truck u-turns might be most helpful on our Florida Intrastate Highway corridors



Jug-handle at a Miami horse race track specifically designed for horse trailers

## 5.4

### U-TURN LOCATIONS

#### U-Turn at Signalized Intersections

Where medians are of sufficient width to accommodate dual left-turn lanes, an excellent option is to allow u-turns from the inside (left-most) left-turn bays as illustrated.

U - turns at signal when:

- Median is of sufficient width
- Low combined left-turn plus u-turn volume at signalized single left-turn .

You should note:

- Consider "right-on-red" restrictions for side streets
- Remember to look at signal operation
- Don't let the signalization work against U-turns



Right turn on red restrictions may be necessary on the side streets to minimize conflicts with U-turns.

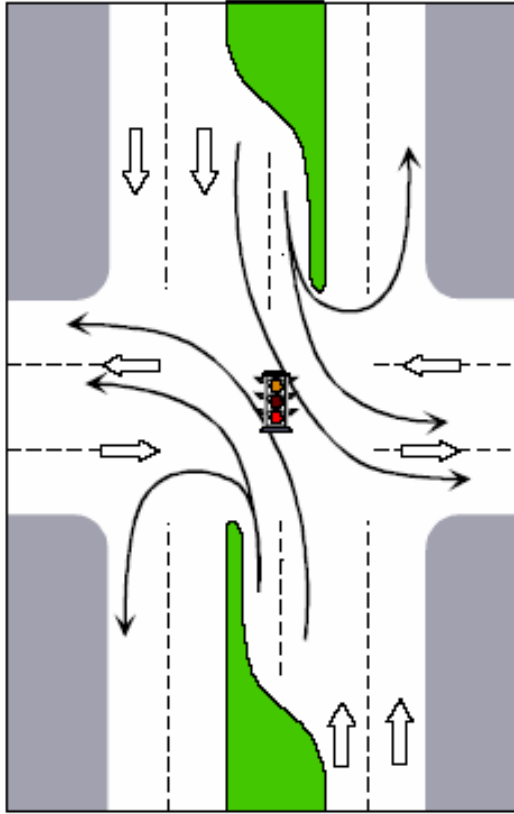

## U-Turns in Advance of a Signal

A u-turn in advance of a signalized intersection will result in two successive left-turn lanes as illustrated in the figure. Unless there is a substantial length of full median width, drivers may mistakenly enter the u-turn lane. And realizing their mistake, make an abrupt re-entry into the through traffic lane. Over one hundred feet of full median width would help avoid this problem. If 100 feet is not possible, signage or other markings can be used to help guide the driver.

Indications that you should consider a U-Turn opening before a signal are:

- Level of Service problems at intersection
- Heavy left turns currently at signal
- High conflicting right turn
- Lanes at signalized side street (where restrictions would hurt)
- Where gap of oncoming vehicles would be beneficial at separate u-turn opening
- Where there is sufficient space to separate signalized intersection and opening

A Study on U-turns by the University of South Florida has shown that having u-turns made before a signalized intersection can greatly decrease delay at the signal.

**Source:** Safety And Operational Evaluation Of Right Turns Followed By U-Turns As An Alternative To Direct Left Turns, Dr. John Lu, University of South Florida

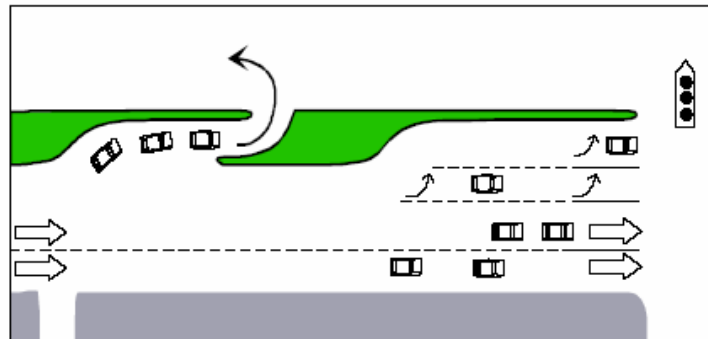



U-turn Before Signal



U-turn Before Signal



**U-Turn After Signal**

Locating the u-turn after a traffic signal has the same separation issues as the U-Turn located before a signal. There should be sufficient space to assure left and U-turns don't become confused on the location of their turn lanes. These have been very popular in Michigan and they are called "Michigan U-turns" or "Michigan Lefts"

### Michigan U Turn Aerial

Source: Maryland State Highway Agency



Depiction of a proposed  
"Michigan U- turn proposed  
in North Carolina

Source: North Carolina DOT



## 5.5

### PLACEMENT IN RELATION TO DRIVEWAYS

Access connections should be located directly opposite or downstream from a median opening as illustrated. Driveway access should be located more than 100 upstream from the median opening to prevent wrong way maneuvers as seen in the figure.

#### ENTRY MANEUVERS

