

# Driveway Information Guide

FLORIDA DEPARTMENT OF TRANSPORTATION 2008

The purpose of this document is to guide the professional through the existing rules, standards and procedures, as well as to provide some background behind the guidelines and best practice for driveway planning.

Unless stated otherwise or specifically referenced, this is not a set of standards or a Departmental Procedure but is a comprehensive guide to assist the professional to make better decisions for driveway placement and design.



**Systems Planning Office**  
State of Florida  
Department of Transportation  
605 Suwannee St. - Station 19  
Tallahassee, Florida 32399  
850-414-4900

[www.dot.state.fl.us/planning](http://www.dot.state.fl.us/planning)



## PURPOSE

The purpose of this document is to guide the professional through the existing rules, standards and procedures, as well as to provide some background behind the guidelines and best practice for driveway planning

Unless stated otherwise or specifically referenced, **this is not a set of standards or a Departmental Procedure** but is a comprehensive guide to assist the professional to make better decisions for driveway placement and design.

**The primary thrust of this handbook is the unsignalized driveway.** Even though much of this material can be used with signalized driveways and intersections, issues of signalized queues and signal timing are not covered in detail.

Historically, the Department has called driveways “Turnouts” in the Design Standards for Design, Construction, Maintenance and Utility Operations, more commonly called the Design Standards or “Standard Index”.

For the Driveway Information Guide the term “Driveway” will be used.

*Please direct questions  
and concerns to your District  
Design Engineer or  
Gary Sokolow  
gary.sokolow@dot.state.fl.us  
850-414-4912*

## Acknowledgements

In addition to all the Team members, we would like to recognize the lifelong work of Dr. Vergil Stover for the impact his work has had on this document.

The material we used to create this document came from many of the important access management documents written over the last 40 years. Specifically though, we borrowed heavily from the following documents. These documents should be used for further illumination of the guidance in this handbook

**Access Management Manual** (Kristine Williams and Vergil Stover)  
– Transportation Research Board – Center for Urban Transportation Research

**Transportation and Land Development** (Vergil Stover) –  
Institute of Transportation Engineers

## Handbook Contributors:

### District Design Engineers

D1: Bernie Masing  
D2: Jimmy Pitman  
D3: John (Scott) Golden  
D4: Howard Webb  
D5: Annette Brennan  
D6: Harold Desdunes  
D7: Dwayne Kile  
Turnpike: Edward (Eddy) Gonzalez

### Other contributors to this and previous version

Gary Amig  
Beth M. Coe,  
Carol Collins,  
Amy Datz  
Ron Fetzko  
Carl Fisher  
Larry Freimuth  
Terry Fleischner  
John Grant  
Tasha Huster  
Ahsan Khalil  
Jim Mills  
Vicente Noboa  
Jim Scott  
Vergil Stover  
Scott Stutson  
Mike Tako  
Jan Thakkar  
Kent Black

## Authors/Editors:

Gary Sokolow, Central Office  
Vergil Stover, Center for Urban Transportation Research  
Frank Broen, Teach America  
Amy Datz, Central Office (Transit and Pedestrian Technical Assistance)



# TABLE OF CONTENTS

---

<b>PURPOSE</b>	<b>3</b>
<b>TABLE OF CONTENTS</b>	<b>5</b>
<b>VISUAL INDEX</b>	<b>7</b>

---

## **1 Introduction**

---

1.1 Introduction ....	9
1.2 What Are Driveways and Why Are They Important? .....	10
1.3 What Are the Critical Driveway Dimensions? .....	11
1.4 Objectives of Driveway Design .....	12
1.5 Highlights of the Design Standards, Standard Index 515 .....	12
1.6 Maintenance of the Driveway.....	17

## **2 Connection Radius and Flare**

---

2.1 Radial Return (Radius) .....	19
2.2 What Does the Standard Index Say About Radial Returns? .....	20
2.3 Effective Radius .....	21
2.4 Flare or Radial Return Decision.....	22
2.5 Designing for Trucks and Other Large Vehicles .....	23

## **3 Driveway Width**

---

3.1 Why Is Driveway Width Important?.....	29
3.2 Radius and Width Work Together.....	30
3.3 Driveway Width In Standard Index 515.....	32
3.4 What Should Determine the Width of the Driveway? .....	33
3.5 Importance of Separate Left Turn Exit Lanes .....	36
3.6 Left Turn Lanes Serving Driveways on Multilane and 2 Lane Roadways.....	36
3.7 Angle of Driveway .....	37

## **4 Driveway Grade**

---

4.1 Importance of Driveway Grade .....	39
4.2 Driveway Grade In Standard Index 515.....	40

## **5 Driveway Channelization**

---

5.1 Channelizing Divisional Islands .....	45
5.2 Size of Divisional Islands In Driveways.....	46

## 6 Driveway Length

---

6.1	Driveway Length .....	51
6.2	Some Guidance from Standard Index 515.....	53
6.3	Driveway Length and Parking Movements .....	55
6.4	Drive Through Queues.....	57

## 7 Right Turn Lanes

---

7.1	Exclusive Right Turn Lanes At Unsignalized Driveways.....	59
7.2	When Should We Build Right Turn Lanes .....	60
7.3	Impact of Large and Slow Moving Vehicles Turning Right .....	61
7.4	Requiring Right Turn Lanes Outside These Criteria .....	62
7.5	How Should the Exclusive Right Turn Lanes Be Designed? .....	63

## 8 Sight Distance at Driveways

---

8.1	Sight Distance at Driveways .....	65
8.2	Stopping Sight Distance (SSD).....	67
8.3	Intersection Sight Distance .....	68
8.4	Sight Distance and Landscaping .....	70
8.5	Criteria For Decisions On Sight Distance and Landscaping Near Driveways and in the Median.....	71
8.6	Sight Distance and On-Street Parking .....	73
8.7	Sight Distance During Construction .....	73

## 9 Driveway Location

---

9.1	Driveway Location .....	75
9.2	Driveways Near Intersections (Corner Clearance).....	77
9.3	Other General Driveway Location .....	77
9.4	Driveway Separation and the 2001 AASHTO Green Book .....	79
9.5	Corner Clearance Downstream on a Minor Side Street .....	80
9.6	Driveway Placement and Median Openings .....	81
9.7	Driveway Placement in Interchange Areas .....	82
9.8	Access Connections on Opposite Sides of a Roadway (Offset) .....	83
9.9	Driveways Near Bus Stops and for Transit Facilities .....	85
9.10	Shared Driveways and Internal Site Interconnection .....	89

## 10 Driveways and the Pedestrian Environment

---

10.1	The Pedestrian and the Driveway Environment .....	93
10.2	Pedestrian Safety in Driveway Design .....	97
10.3	FDOT Driveway and Sidewalk Design Criteria.....	98
10.4	Striping for Exclusive Right-Turn Lanes with Bicycle Lanes .....	100

Appendices .....	*
------------------	---



## INTRODUCTION

### 1.1

#### INTRODUCTION

Driveways provide the physical transition between a site and the abutting roadway. Driveways should be located and designed to minimize impacts on traffic while providing safe entry and exit from the development served. The location and design of the connection must take into account characteristics of the roadway, the site, and the potential users. Another important factor to consider is if the driveway redesign is done during the design of a roadway improvement (such as resurfacing vs. major reconstruction).

## 1.2

### WHAT ARE DRIVEWAYS AND WHY ARE THEY IMPORTANT?

*Driveways are intersections*

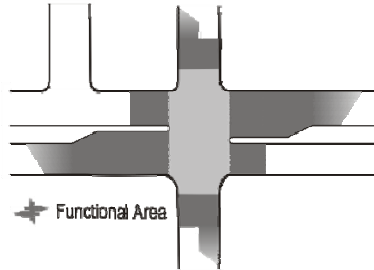

As defined by the American Association of State Highway and Transportation Officials (AASHTO), a driveway is an access constructed within the public right of way, connecting the public roadway with adjacent property. AASHTO also considers driveways intersections. You should place the driveway in a manner to minimize conflicts with the roadway and sidewalk.

### Driveway Permitting and Standards

All new driveways associated with a new or expanded development must be permitted through the process in the ***Florida Administrative Chapter 14-96***, State Highways System Connection Permits, Administrative Process. The separation standards for driveway separation are found in *Rule 14-97.003, State Highway System Access Management Classification System and Standards*. (Exhibit 1)

Driveways that are modified by The Florida Department of Transportation, due to roadway improvements, do not need to go through the full permitting process.

#### Exhibit 1 SPACING STANDARDS

Posted Speed  
\* > 45 mph/  
≤ 45 mph

Class	Median Type	Connection Spacing (feet)		Median Opening Spacing (feet)		Signal Spacing (feet)
		≤45mph Posted	>45mph Posted	Directional	Full	
<i>Generally Developing or Undeveloped</i>						
<b>2</b>	Restrictive w/Service Roads	660	1320	1320	2640	2640
<b>3</b>	Restrictive	440	660	1320	2640	2640
<b>4</b>	Non-Restrictive	440	660			2640
<i>Generally Developed</i>						
<b>5</b>	Restrictive	245	440	660	2640/1320*	2640/1320*
<b>6</b>	Non-Restrictive	245	440			1320
<b>7</b>	Both Median Types	125		330	660	1320

## 1.3

### WHAT ARE THE CRITICAL DRIVEWAY DIMENSIONS?

In order to assure that driveways are designed to provide for safe and efficient movements, it is necessary to pay attention to their critical dimensions and design features. This section will describe these features and give recommendations for their proper design as illustrated in Exhibit 2.

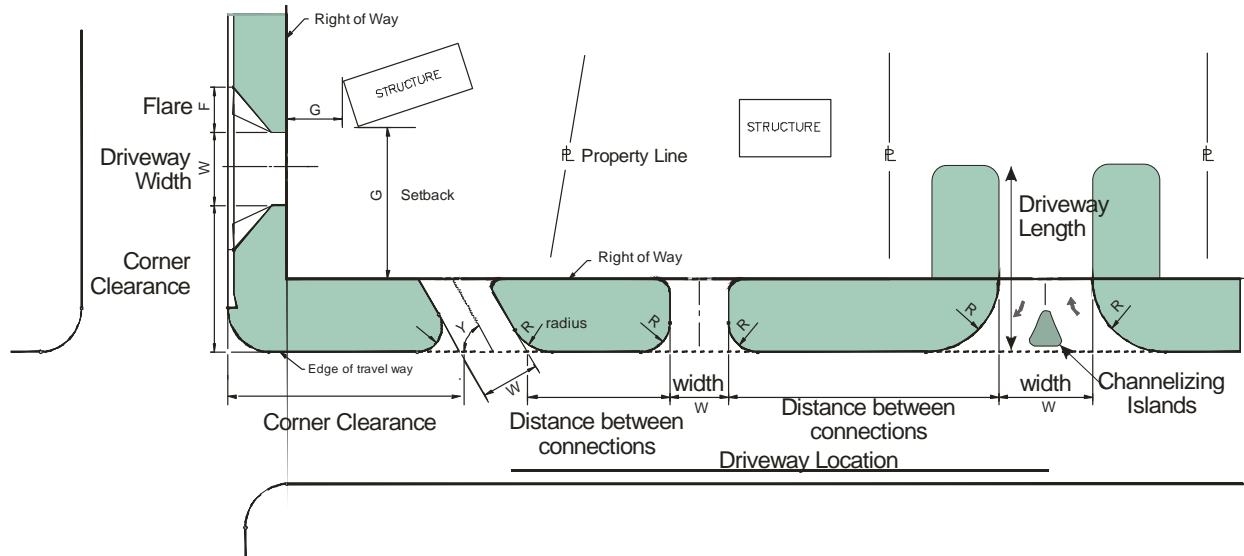

Exhibit 2  
**DRIVEWAY  
DIMENSIONS**

Source: Adapted from FDOT  
Design Standards, Standard  
Index 515

- **Radius (R)** – size of curved approach/exit of driveway
- **Flare (F)** – size of angled approach/exit of driveway
- **Width (W)** – space for vehicles operating on driveway
- **Driveway Distance (D)** – or spacing between driveways
- **Corner Clearance (C)** – similar to (D) but measured from a major intersection
- **Angle (Y)** – angle of driveway
- **Setback (G)** – distance from public right of way to the closest structure
- **Sight Distance** – length of road visible to the driver required for vehicles to make safe movements
- **Driveway Location** – position of driveway in relation to other traffic features such as intersections, neighboring driveways, and median openings
- **Driveway length** – (also called “throat length”) distance needed into site to transition vehicles to the internal circulation system of the site
- **Grade** – slope of driveway
- **Driveway Traffic Separators/Channelizing Islands** – size and position of barrier separating traffic movements on the driveway
- **Right Turn Lanes** – separate lanes on roadway to facilitate right turns into driveway
- **Structure** – Building, Gas Island, Gate, etc.

## 1.4

### OBJECTIVES OF DRIVEWAY DESIGN

The following objectives should be kept in mind when applying any criteria in the design of driveways. The design should:

- Provide traffic lanes within the driveway to produce efficient traffic flow for vehicles entering and leaving the site.
- Provide a clear and safe environment for all road users (cars, applicable vehicle types, cyclists, bus patrons, and pedestrians, including the disabled).
- Minimize the difference in speed between turning vehicles and through traffic.
- Minimize encroachment of turning vehicles on adjacent lanes.
- Provide adequate sight distance for drivers using the driveway (entering, exiting and approaching traffic).
- Provide sufficient operational area for traffic entering the site to prevent a “spillover” queue onto the public street.

## 1.5

### HIGHLIGHTS OF THE DESIGN STANDARDS, STANDARD INDEX 515 for this Document:

Historically, the Department has called driveways “**Turnouts**” in the *Design Standards for Design, Construction, Maintenance and Utility Operations*, more commonly called the *Design Standards* or “**Standard Index**”.

For the **Driveway Information Guide** the term “**driveway**” will be used.

**Standard Index 515** has divided driveways into four major categories to help us get the most appropriate design standards. Generally, the higher the volume on the driveway, the more important it is to use more stringent design standards. Exhibit 3 provides information regarding the divisions and examples of land uses that are expected to produce this traffic.



Driveway Categories in Design Standards - Standard Index 515

<b>DRIVEWAY CATEGORIES DEFINED STANDARD INDEX 515</b>
1-20 trips/day or 1-5 trips/hour
21-600 trips/day or 6-60 trips/hour
601-4,000 trips/day or 61-400 trips/hour
Over 4,000 trips/day or over 400 trips/hour

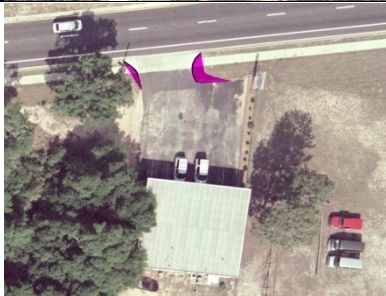

Exhibit 3

*Driveways should be designed based on the expected volume and type of traffic*

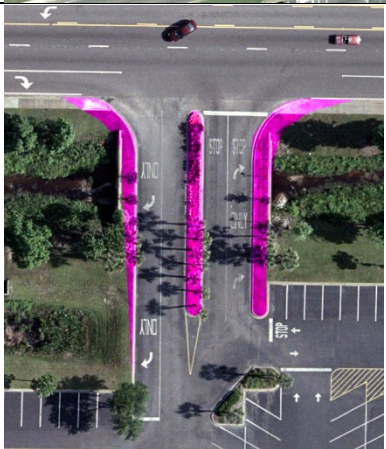
Expected Driveway Trips	Example Land Uses	How to Design Driveway
	1-20 trips/day or 1-5 trips/hour	(Guidance not found specifically in Index 515)  Usually minimum requirements – possibly some high speed features in rural high speed locations
	21-600 trips/day or 6-60 trips/hour	3 to 60 housing or apartment units  Small office in converted home  “Mom & Pop” business  Driveway with some high volume features (possibly radial return, turn lanes, or other features)
	601-4,000 trips/day or 61-400 trips/hour	Small “Strip” shopping center (20-75,000 sq. ft.)  Gas station/ convenience market
	<b>Over the Range of Standard Index 515</b>  Over 4,000 trips/day  Over 400 trips/hour	150,000 ft shopping center  Grocery/drugstore with 10-15 smaller stores  (9,000 daily trips split w/2 driveways)  Design as full intersection in cooperation with the local government  <u>(See General Note 6 in Standard Index 515)</u>

Differences in Flare vs. Radial Return Driveways

There are also two basic forms of construction for driveways. They are the “**Curbed Flared Driveway**”, (sometimes called the Dropped Curb) and the “**Radial Return**”.

Where roadway **curb and gutter** construction is present (called “**Urban**” style roadway in the Design Standards *Standard Index*), “Curbed Flared Driveway” design is prevalent except for higher volume driveways. Where a flush shoulder design of roadway is present (called “**Rural**” style roadway in the *Standard Index*), all driveways should use the rounded **Radial Return** design.

Urban design driveways are not restricted to urban areas. Even though curb and gutter is called “**urban**” in Florida, these styles of roadway may be found in rural areas. You will also find quite a few “**rural**” (meaning flush shoulder) roadways in dense urban areas.

Exhibit 4  
**Standards For Flush  
 Roadway - "Rural"  
 Section Flush Shoulder**

“Rural Section”

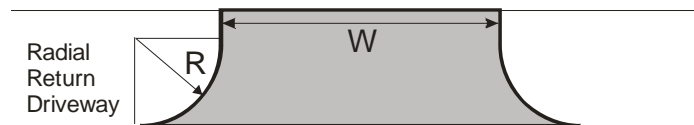

**Note on Width:**

When more than 2 lanes in the connection are required, the 36’ maximum width may be increased to relieve interference between entering and exiting traffic, which adversely affects traffic flow. These cases require site documented, site-specific study and design. (Note from *Standard Index 515.*)

<i>Trips/Day</i>	1-20	21-600	601-4000
<i>Trips/Hour</i>	1-5	6-60	61-400
<b>Connection Width – W</b> (feet) (See note on width)	(1- way) 12’ min * (2- way) 24’ max	(2 – way) 24’ min 36’ max	(2 – way) 24’ min 36’ max
<b>Returns</b> (Radius) - R (feet)	15’ min 25’ std 50’ max	25’ min 50’ std 75’ max	25’ min 50’ std (or 3 curves)
<b>Angle of Drive - Y</b> (degrees)	N/A	60° – 90°	60° – 90°
<b>Divisional Island – Connector Traffic Separator</b> (feet)	N/A	4’ to 22’ wide	4’ to 22’ wide

\* for single family dwelling unit driveways only





Exhibit 5  
**STANDARDS FOR CURB  
 AND GUTTER -  
 "URBAN" SECTION**

**Curb & Gutter or "Urban Section"**

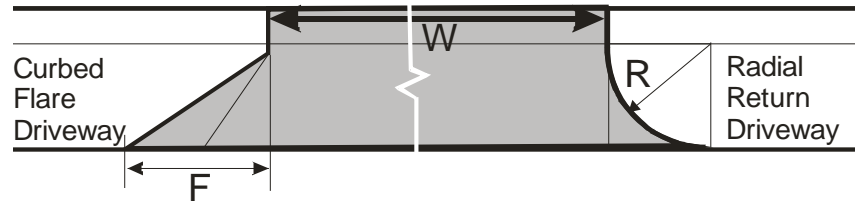

**Note on Width:**

When more than 2 lanes in the connection are required, the 36' maximum width may be increased to relieve interference between entering and exiting traffic, which adversely affects traffic flow. These cases require site documented site-specific study and design. (Note from *Standard Index 515.*)

<i>Trips/Day</i>	1-20	21-600	601-4000
<i>Trips/Hour</i>	1-5	6-60	61-400
<b>Connection Width - W</b>	(1- way) 12' min (2- way) 24' max	(2- way) 24' min 36' max	(2- way) 24' min 36' max
<b>Flare (Drop Curb) - F</b>	10' min	10' min	N/A
<b>Returns (Radius) - R</b>	N/A	10'-35' <i>but not in Standard Index<sup>(1)</sup></i>	25' min 50' std 75' max
<b>Angle of Drive - Y (degrees)</b>	N/A	60° - 90°	60° - 90°
<b>Divisional Island - Connector Traffic Separator</b>	N/A	4' to 22' wide	4' to 22' wide

(1) Small radii may be used in lieu of flares as approved by the Department



**See Section 2.4 of the Driveway Information Guide** for more detail on the decision between "Flare Drop Curb" or "Radial Return"

Using all minimum standards can lead to problems

Many of the design features work together to assure proper operations. For instance, a driveway with a small radial return can operate well if the width of the driveway is larger. Also, certain difficult driveway angles can operate better with a greater turning radius. See Section 3.2 for more information on how radius and width work together to provide the best driveway design.

## 1.6

### MAINTENANCE OF THE DRIVEWAY

Once a driveway is constructed, the property owner is generally responsible for maintaining the pavement, signing and striping and other features installed for operations on the connection. The Department or another governmental agency will be responsible for the features necessary for the operations of the major roadway, and on auxiliary lanes, such as, exclusive right turn lanes.

For curb and gutter sections with sidewalk

***FAC Rule 14-96.016*** also states that the Department will be responsible for maintenance to the back of the sidewalk.

For driveways on non-curbed or rural sections Department maintenance will extend 5 feet beyond the edge of the roadway pavement.



**Exhibit 6  
Limits Of Construction  
And Maintenance For  
Flush Shoulder "Rural"  
Section Connections**

*Source: Adapted from  
Standard Index 515, sheet 5  
and Rule 14-96.016*

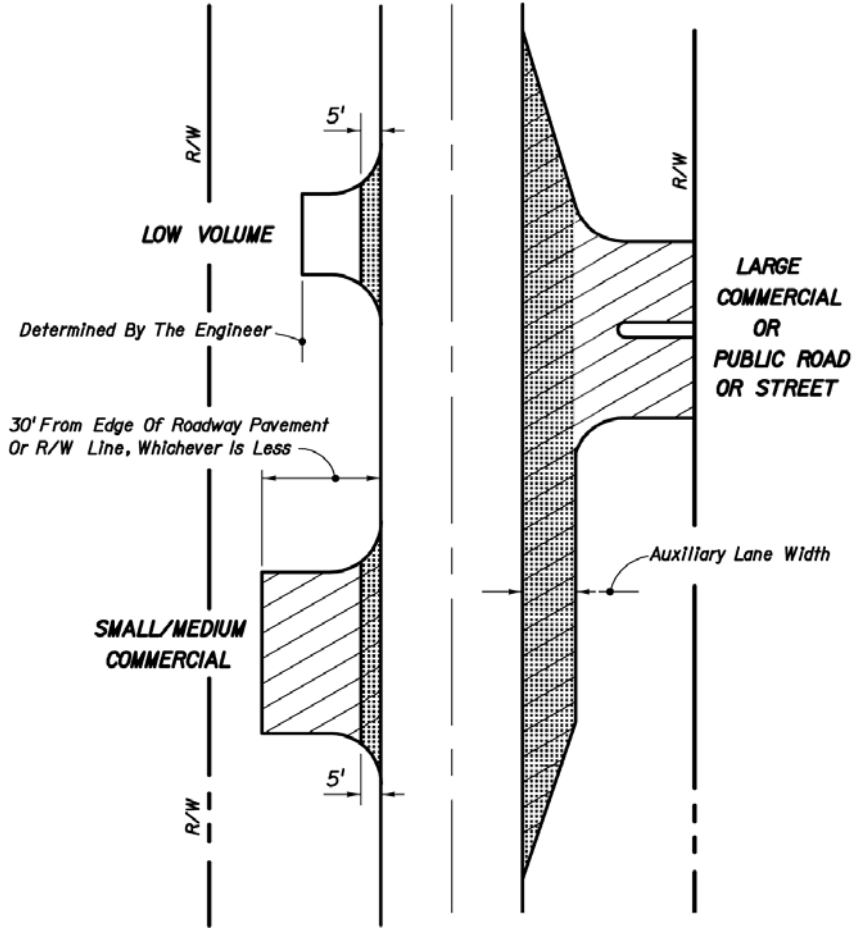
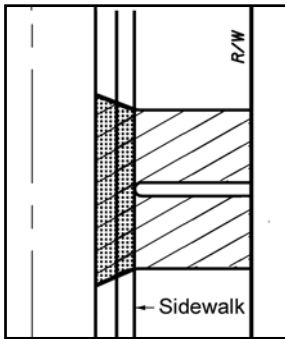
**Exhibit 6  
"Urban" Section Limits  
Of Construction**



**LEGEND**

-  Graded Or Paved
-  Required Paving
-  Limits Of Department Maintenance



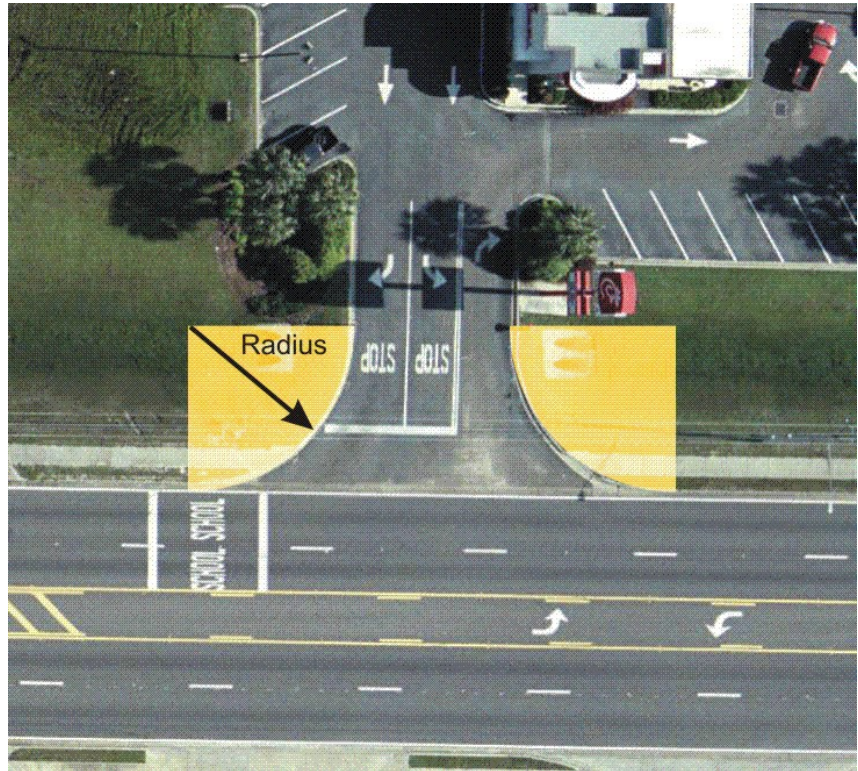

## CONNECTION RADIUS AND FLARE

### 2.1

#### RADIAL RETURN (RADIUS)

The turn radius of a radial return driveway refers to the extent that the edge of a driveway is “rounded” to permit easier entry and exit by turning vehicles. A larger radius results in easier entrance or exit movements for vehicles. The driveway movement can be performed at a higher speed and without encroachment into other roadway and driveway lanes. This reduces interference with the traffic on the major roadway but at the same time may produce larger openings that can hinder pedestrians. [See Exhibit 7.](#)

Exhibit 7  
**RADIUS AND WIDTH  
 WORK TOGETHER**

See Section 3.2 for more information on how radius and width can be used together

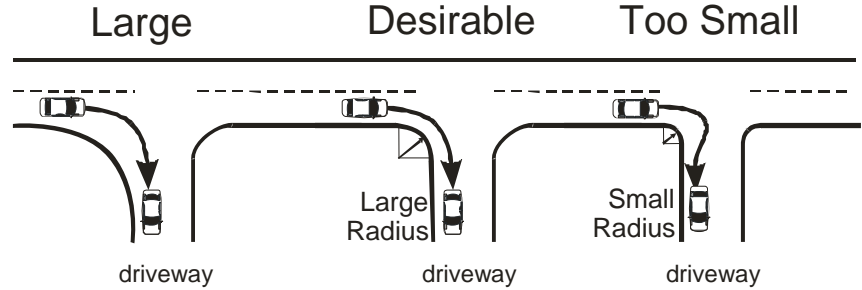

**2.2**

**WHAT DOES THE  
 STANDARD INDEX SAY  
 ABOUT RADIAL  
 RETURNS?**

Radial returns are covered under the Department's **Standard Index 515** as a function of both the daily trips at the driveway and the type of section, "urban" (curb & gutter) or "rural" (flush). See Exhibit 8.

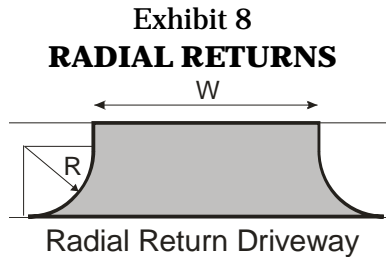

A 50 ft radius is not always needed

<i>Trips/Day</i>	1-20	21-600	601-4000
<i>or Trips/Hour</i>	<i>or 1-5</i>	<i>or 6-60</i>	<i>or 61-400</i>
<b>RURAL SECTION</b> Radius (feet)	15' min 25' std 50' max	25' min 50' std 75' max	25' min 50' std (or 3-centered curves)
<b>URBAN SECTION</b> Radius (feet)	N/A *	10'-35'	25' min 50' std 75' max

\* Small radii may be used in lieu of flares as approved by the department

Any connection requiring or having a specified median opening with left turn storage and served directly by that opening shall have radial returns.

In many cases a radius of 25 to 35 ft. will be more sensitive to pedestrian movements across the driveway.

The 50 to 75 ft radius is most appropriate where large vehicles will be common See Section 2.5, Designing for Trucks and Other Large Vehicles

## 2.3

### EFFECTIVE RADIUS

When a driveway intersects a roadway with on-street parking or bike lane, the extra pavement width can increase the effective turning radius by 6-14 ft. (depending on the width of the parking or bike lane). When necessary, the actual curb radius may be reduced by conditions we can't change. Using effective radius in order to meet minimum standards should only be done where absolutely necessary since future roadwork may include moving the parking and bike lanes.

Exhibit 9  
*Bike lanes can add to the effective radius of the driveway – but use it wisely*

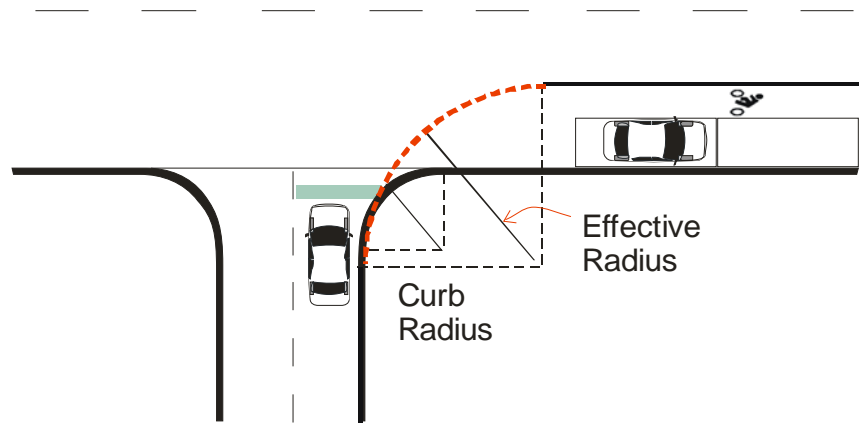

## 2.4

### FLARE OR RADIAL RETURN DECISION

In curb and gutter sections, determine whether a radial return or a drop curb flare is the best design. The Standard Index 515 requires the Radial Return Design on driveways expecting to carry more than 600 trips per day. However, there are many advantages to using the radial design on commercial driveways having less than 600 trips per day.

The design of the flare or radial return determines the speed and ease in which a vehicle can get in and out of a driveway. Generally, the larger the radius or flare, the quicker and more efficiently a vehicle can get in and out. This reduces interference with traffic on the major roadway, but at the same time produces larger openings and higher vehicle entry speeds that may hinder pedestrian use of the sidewalks. The major considerations for this decision are:

- Speed of traffic on major roadway.
- Amount of traffic expected on the driveway (especially the chances of a vehicle in the driveway attempting to exit as another vehicle enters).
- Amount of available right of way, since the radial return may require more land.
- Vehicle type (Design Vehicle) typically present.

#### Where to Always Use Radial Return

The proper application of the flare and radial return depends on the conditions and use of the driveway. For a rural section where a flush shoulder exists, a radial return is always used.

- Sometimes it will be necessary to use an exclusive right turn lane to have good operations. In these cases, you will always use a radial return design. **[See Chapter 7 - Right Turn Lanes](#)** for more information.
- **[See Section 2.5](#)** - Flare driveway construction is also handled in the Department's ***Standard Index 515***. Flare driveways are usually acceptable for low volume driveways in areas where a curb and gutter exists, and the driveway will have less than 600 trips per day. Even if trips are expected to be below 600 per day, radial return design usually leads to better operations and access.



## 2. 5

### DESIGNING FOR TRUCKS AND OTHER LARGE VEHICLES

Due to the large size of trucks and buses we need to consider different dimensions for their movement. However, if we designed all connections for large vehicles the resulting design may not work well for passenger cars and pedestrians. This is due to the extra large area for traffic movement that could make it confusing to the drivers of passenger cars and also make too wide an area for pedestrians to cross. Therefore, **driveways designed specifically for trucks and buses should usually be done when it handles more than two or three trucks or buses per hour.** [See Exhibit 10](#) for more details. Examples of facilities you would design for truck sized dimensions are:

Example Dimensions for the Single Unit Vehicle

- Truck facilities
- Bus terminals – Including “Park and Ride” and other transit transfer stations
- Connections serving buses to shopping center or mall transit transfer points
- Connections serving loading docks of shopping centers and malls
- Delivery and inter-modal facilities (ports, railroad yards, etc.)

Exhibit 10 provides suggested design criteria for designing driveways for trucks, buses and large vehicles.

**Exhibit 10  
SUGGESTED  
DRIVEWAY DESIGN  
CRITERIA BASED ON  
TRUCK OR LARGE  
VEHICLE USE**

<b>Commercial and office uses</b> (shopping center, office complex, convenience store)		
<b>Number of Trucks or Buses Per Hour</b>	<b>Operation to Design for</b>	<b>Design Vehicle<sup>3</sup></b>
≤ 2	Simultaneous 2-way	P <sup>1</sup> or a Standard Passenger Vehicle
≥ 3	Simultaneous 2-way <sup>2</sup>	Single Unit vehicle (typical FedEx or UPS Truck)
<b>Industrial Uses</b> (distribution centers, warehousing)		
	Simultaneous 2-way	Typical multi-unit tractor trailer
<b>Other Uses</b>		
Truck stop	Simultaneous 2-way <sup>3</sup>	Largest vehicle <sup>4</sup>
Transit Center/ Bus Terminals	Simultaneous 2-way	Largest bus
Recreational with RVs and trailers	Simultaneous 2-way	Motor home with trailer

<sup>1</sup>A standard passenger car (P vehicle) can enter while another standard passenger car (P vehicle) is waiting to exit.

<sup>2</sup>A standard delivery Single Unit truck (SU vehicle) can enter when a standard passenger car (P vehicle) is waiting to exit.

<sup>3</sup>Designed so that larger vehicles can off-track through the driveway.

<sup>4</sup>Interstate semi-trailer and turnpike double trailer will be the design vehicle in many states, especially in the vicinity of freeway interchanges.

*Source: Adapted from Transportation and Land Development, 2002, Stover (pages 7-12).*

Three Centered or Compound Curves for Handling Trucks Instead of Large Radii

In order to have the best design for trucks, the use of compound curves rather than a simple radial return has many advantages (**See Exhibit 11** for an example), including the following:

- The total driveway width is reduced;
- Where the driveway is designed primarily for autos, the occasional truck can be better accommodated; and
- When the driveway is designed for trucks, the narrower exit lane width and geometrics of the connection provide better positive guidance to automobile drivers.

Using a compound curve rather than a simple curb return radial return of 30 ft. will permit the driver of a passenger car to exit a driveway without encroaching on the through lanes.

*Source: Adapted from Transportation and Land Development, Stover, 2002, Chapter 7*

Exhibit 11  
**Equivalent Compound  
 Curves Geometrics For  
 Departure Radii**

The *AASHTO Green Book* also gives guidance on the use of compound curves. Exhibit 12 is an example for the design of a WB-62 using compound curves for a 90-degree turn.

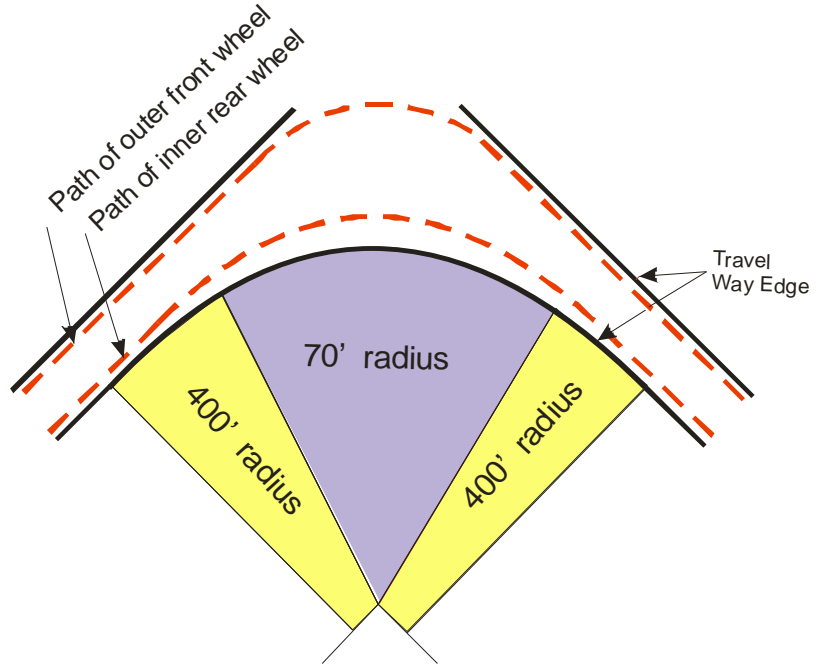

WB-62 SEMITRAILER COMBINATION

Exhibit 12  
**TURNING TEMPLATE  
 FROM AASHTO**

Typical Turn Template for  
 Design Vehicle

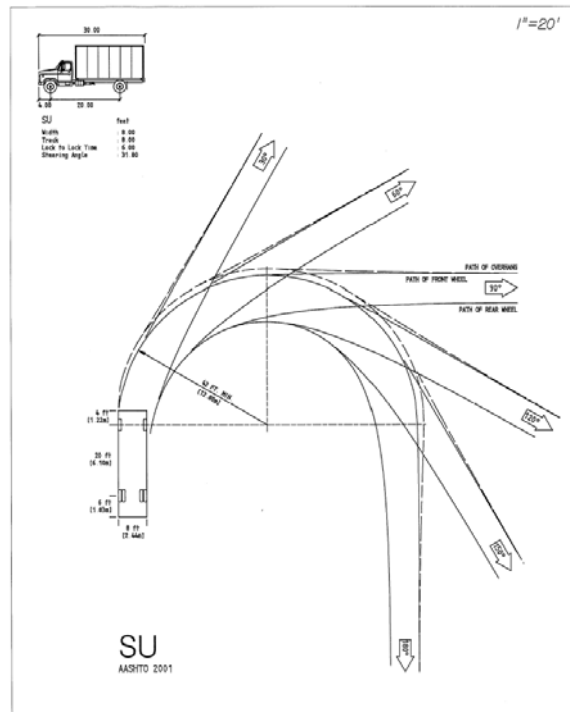

Exclusive Right Turn Lanes  
 for Trucks

**Consider Exclusive Right Turn Lanes to Help Trucks and Buses Move Off the Road More Safely.**

To turn into a driveway, trucks and other large vehicles need to slow down considerably. This can cause considerable disruption for the through movement traffic. [See Chapter 7](#) for more information on exclusive right turn lanes.





## DRIVEWAY WIDTH

### 3.1

#### WHY IS DRIVEWAY WIDTH IMPORTANT?

Driveway width is important because it has a dramatic impact on the ease of entry into the driveway, similar to the radius and flare decision. The more quickly a vehicle can enter a driveway, the less chance there is of a rear end collision or congestion caused by following through vehicles slowing down for vehicles entering driveways.

On the other hand, a driveway can be too wide. Excessive width leads to a situation where the driver is not guided to the best position for driveway movements. Excessive width and radius can result in excessive pedestrian and cyclist exposure to vehicles. [See Chapter 10](#) for more information on the pedestrian impacts of driveways.

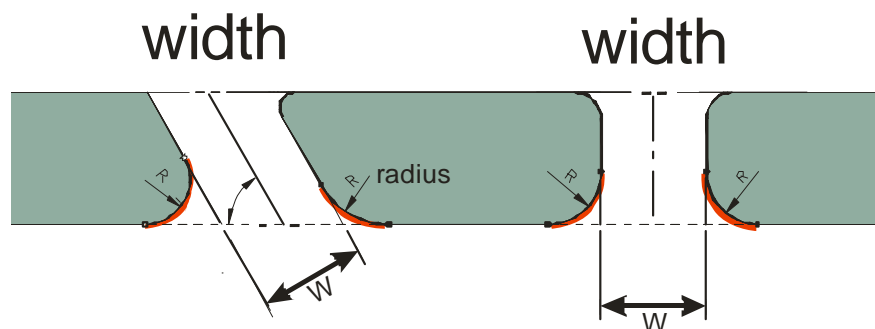

Source: Adapted from Standard Index 515

### 3.2

## RADIUS AND WIDTH WORK TOGETHER

It's important to know the operational impacts of radius and width before you set a final design

**Tip** – use pavement markings when driveways are 36 ft or more



**Exhibit 14  
MEASURES  
IMPORTANT TO  
DETERMINING THE  
ENTRY OPERATIONS  
OF A DRIVEWAY**

Driveway width and radius can be used in combination to create good driveway operation. Generally, a wide driveway can be used in combination with a small radius or flare to achieve similar operations. The guidance that follows are combinations of width and radius that provide for the entering passenger vehicle at approximately 10 mph to enter without encroaching on an outbound driveway vehicle. The paved shoulder (Exhibit 14) provides extra effective radius as shown in **Section 2.3, Effective Radius**. For driveways with expected volumes of less than 20 per day (a single home or duplex), it may not be necessary to design for “the no encroachment standard” with an outbound vehicle.

Excessive width can be a problem to both drivers and pedestrians. **If a driveway is over 36 ft wide, pavement markings or channelization is generally needed** to help guide the driver to the appropriate portion of the driveway.

Without the guidance of markings, drivers exiting a driveway tend to position themselves left of the driveway center. Double yellow paint lines help in guiding exiting drivers to the proper exit position. This helps ensure that the intended driveway width is available to drivers making an entry maneuver.

*Source: Transportation and Land Development, 2002, Stover*

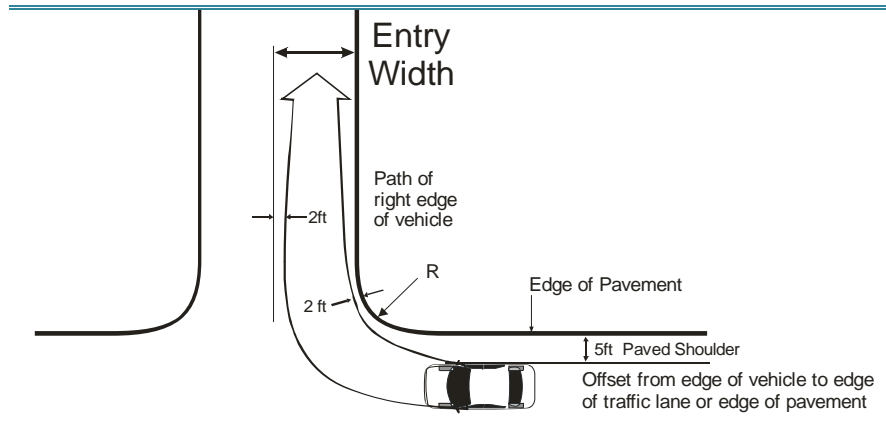

## Single Entry Lane Width for a 90 Degree Right Turn-In

### Important Notes For Use of Exhibit 15

See [Section 2.5](#) for more on Truck Entry

Exhibit 15 provides information for entry lane widths and return radii for passenger cars traveling at forward speed of approximately 10 mph, two-way driveway operation with simultaneous entry and exit maneuvers.

This exhibit clearly shows the advantages of radial return driveways for vehicle operations and use of space. The typical flared driveway operates at the equivalent of less than 3 ft of radius.

- A wider driveway is required if simultaneous two-way operation with a truck or bus is desired.
- A driveway with a radius of greater than 25 feet requires a 14 foot entry width and is not impacted by the presence or lack of a bike or parking lane.
- If you are using flare, radius or width measures outside of those in **Standard Index 515**, you will need to document the need, and it should be approved by the Department.

Physical channelization in the driveway would add at least 2 ft to these measurements.

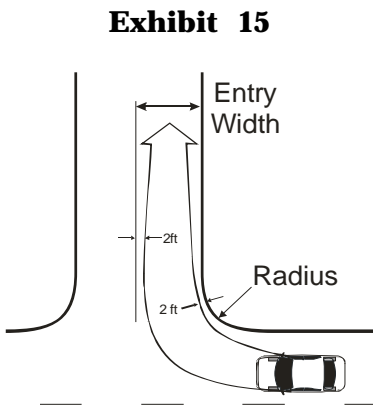

Radius or Flare (ft.)	Single Lane Width for Entry for Passenger Vehicles (ft.)
Typical flared driveway	22 ft (Pavement striping should be used if entry is this wide)
10 ft Radius	19 ft
15 ft Radius	17 ft
20 ft Radius	14 ft
25 ft Radius	14 ft
Over 25 ft Radius	12-14 ft

Source: adapted from *Access Management for Streets and Highways*, Flora and Keith, FHWA, 1982 p 63

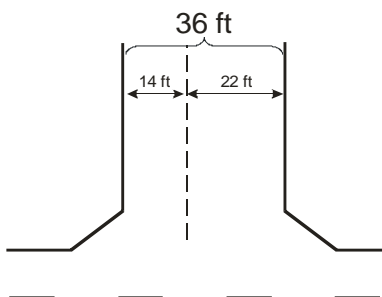

- If a 22 foot entry lane is used, a 14 foot exit lane can be used to stay within the 36 foot maximum total from **Standard Index 515**. In this case, lanes should be striped to clearly show the movement areas.

### 3.3

#### DRIVEWAY WIDTH IN STANDARD INDEX 515

Exhibit 16  
**CONNECTION WIDTH  
(2-WAY)**

**Standard Index 515** has width standards for basic driveways of differing driveway traffic volumes.

	<i>Trips/Day</i>	<i>1-20</i>	<i>21-600</i>	<i>601-4000</i>
	<i>Trips/Hour</i>	<i>1-5</i>	<i>6-60</i>	<i>61-400</i>
RURAL SECTION (Flush Shoulder)		12' min 24' max	24' min 36' max	24' min 36' max
URBAN SECTION (Curb & Gutter)		12' min 24' max	24' min 36' max	24' min 36' max

These widths do not specifically take into account traffic separators in the driveway, pavement markings or striping, extra turn lanes in or out, and locations with a high-expected truck or large vehicle use. Those factors will add width to the dimensions of the driveway and some times these necessary additions will make the driveway width exceed the 36 foot maximum found in the table on *Standard Index 515*. Therefore, the following note has been added to the *Standard Index 515*:

“When more than 2 lanes in the turnout connection are required, the 36 foot maximum width may be increased to relieve interference between entering and exiting traffic which adversely affects traffic flow. These cases require site documented, site-specific study and design.”



### 3.4

#### WHAT SHOULD DETERMINE THE WIDTH OF THE DRIVEWAY?

One of the keys to a good driveway design is the goal of serving the entry and exit movements separately so the movements don't encroach on each other. This will allow a vehicle to enter without encroaching on the area needed for a vehicle to exit the driveway. Once these movements and the desired measurements are determined, you need to see how these design criteria interact with each other.

Driveway design to facilitate efficient and safe movement may be accomplished by looking at the following factors:

Design specifically for the entry and exit movements

- Driveway entry
- Driveway exit
- The interaction of entry and exit with the number of driveway lanes

#### Entry Area of the Driveway

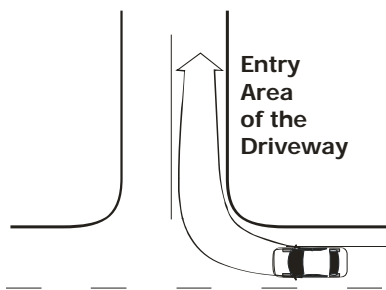

The entry area is probably the most critical portion of driveway width. Vehicles may be turning left, as well as right into the driveway. The entry width should be sufficient to allow a vehicle to:

- Enter without having to slow down to nearly a stop in the through lanes
- Make a right turn into the driveway when an exiting vehicle is waiting and not encroach on the exiting vehicle.

Exhibit 17  
**ENCROACHMENT DUE TO INADEQUATE DRIVEWAY DESIGN**

*Adapted from Vergil Stover's Class notes*

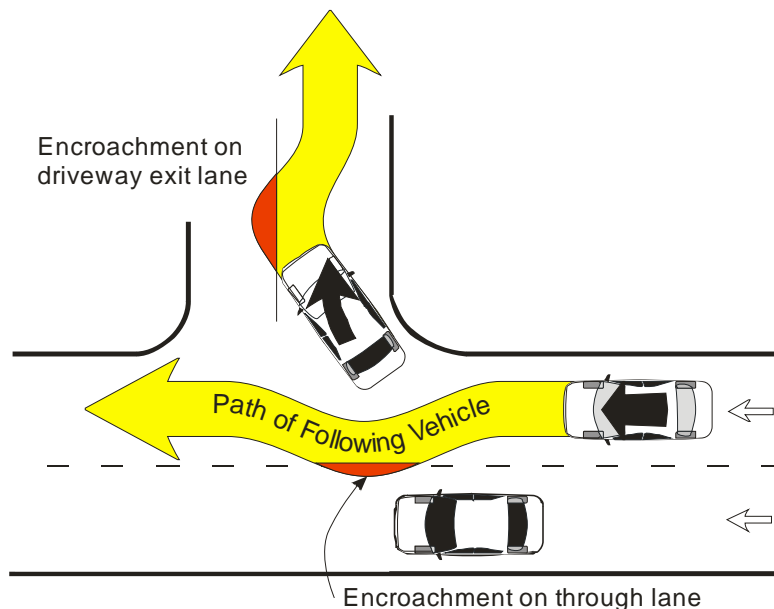

## Exit Area of the Driveway

The exit area lanes need to serve the operation of outbound driveway traffic.

Vehicles may be turning right, left, or crossing the main roadway. This portion of the driveway needs to be wide enough to:

- Allow vehicles to turn right onto the public street or driveway without encroaching on the through lanes in the opposite direction;
- Allow the number of exiting driveway lanes necessary for efficient outbound operation of the driveway. Driveways may need separate outbound lanes (usually a left turn lane) to prevent excessive queues in the driveway area;
- Allow a right-turning vehicle to exit the access connection without encroaching upon the adjacent lane of a multi-lane highway or upon the opposing lane of a 2-lane highway.

Exhibit 18  
**ENCROACHMENT DUE  
TO INADEQUATE  
DRIVEWAY DESIGN**

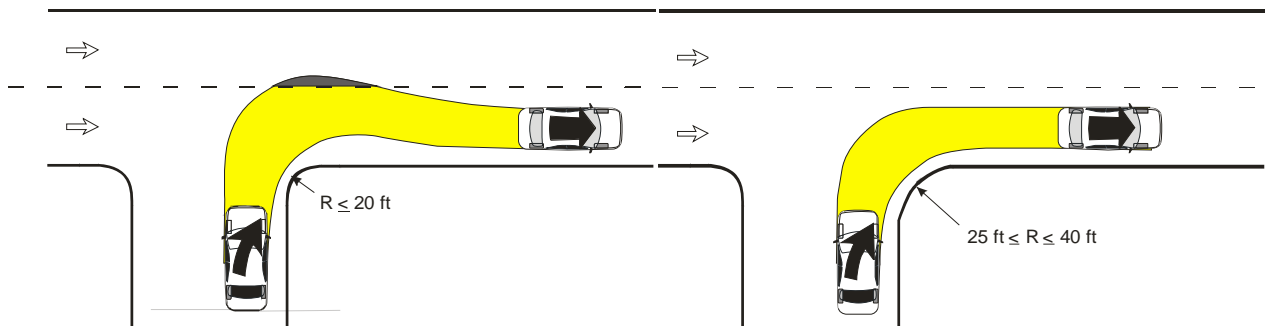
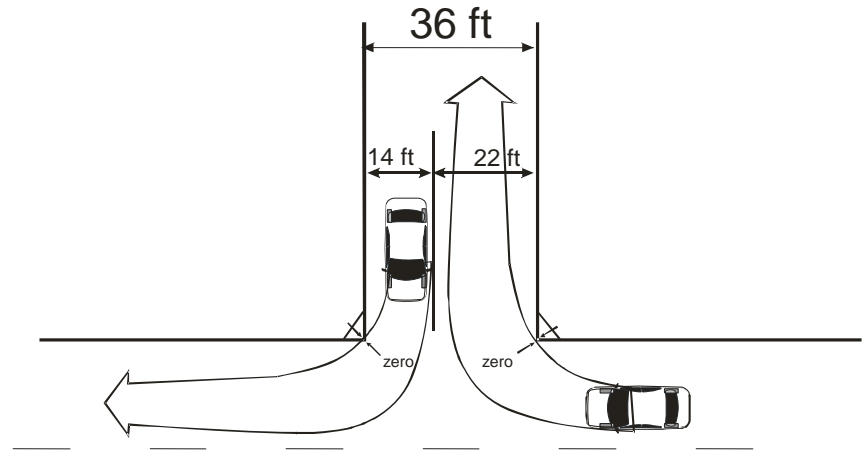

Exhibit 19  
**FLARED DRIVEWAY VS.  
 RADIAL RETURN**



Dropped Curb

**Flared Driveway**

With the Flared Driveway you need 8 extra feet of driveway width to get the same operations as a 10 foot radius with the typical Passenger Car (“P” Vehicle)

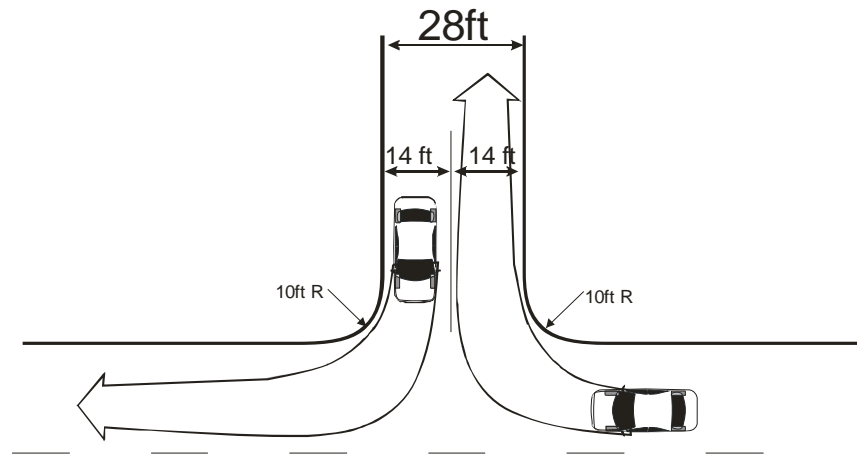

Curb Return Radius

*Source: Adapted from Transportation and Land Development, Vergil Stover 2002*

### 3.5

#### IMPORTANCE OF SEPARATE LEFT TURN EXIT LANES

Where left-turns exiting the driveway are permitted, separate left-turn and right-turn lanes should be considered on commercial driveways. Even a small number of left-turns will cause substantial delay to right-turns out when the driveway has a single lane exit. This driveway layout is most needed where expected driveway volumes exceed 600 daily. They may also be beneficial as low as 300 daily trips traffic depending on the character of the exiting traffic.

#### Exhibit 20 3 LANE DRIVEWAYS

When driveway volumes exceed 600 per day, a three-lane cross-section should be considered

Consider channelization if traffic is over 4,000 per day

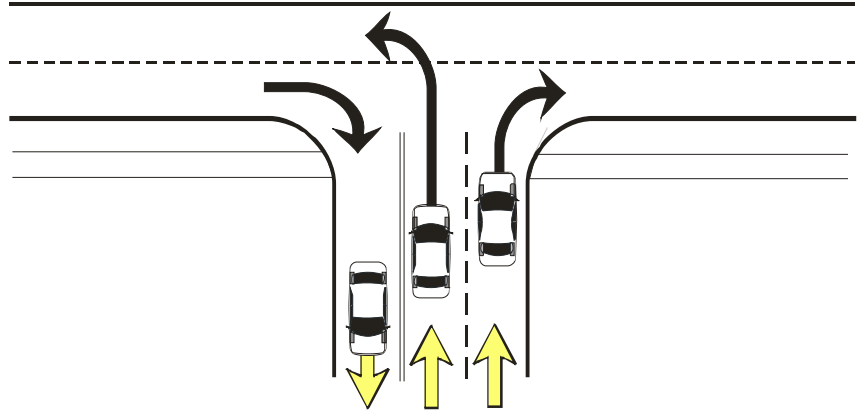

Source: Adapted from Vergil Stover's unpublished course notes

### 3.6

#### LEFT TURN LANES SERVING DRIVEWAYS ON MULTILANE AND 2 LANE ROADWAYS



On a multilane roadway with a median

Whenever a driveway is directly served by a median opening, a left turn lane should be available. This provides for the safest left turns into the driveway.

On a two-lane roadway

Exclusive left turn lanes should be considered at any location serving the public, especially on curves and where speeds are 45 mph and higher.

The AASHTO Green Book contains guidance on this issue. However, the guidelines were developed based on delay rather than crash avoidance. Safety is the main reason behind exclusive left turn lanes.

### 3.7

#### ANGLE OF DRIVEWAY

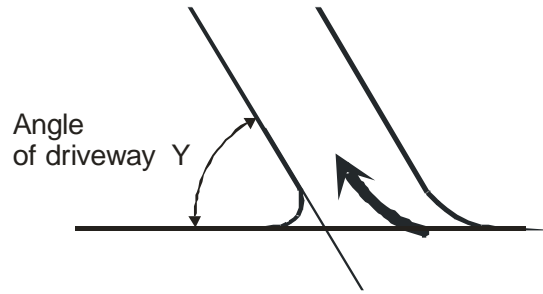

Angle of Driveway in  
*Standard Index 515*

Exhibit 23  
**ANGLE OF DRIVE**

For reasons of driver expectancy, driveways should generally be at 90° to the main roadway. However, other angles can be used where desirable.

Guidance for angle of drive is shown in ***Standard Index 515***. A range of 60° and 90° is given for both urban and rural sections in Exhibit 23 below.

<i>Trips/Day</i>	1-20	21-600	601-4000
<i>Trips/Hour</i>	1-5	6-60	61-400
<b>Angle of Drive Y</b>	NA	60°-90°	60°-90°

Angles between driveways and abutting roadways other than a right angle tend to increase the driveway intersection area and thereby increase the exposure time of conflicting vehicular movements. However, angles between 60 and 90 degrees normally do not interfere with the visibility for auto drivers.

If 14' lanes are used in the driveway, all reasonable combinations of radius (15 ft–50 ft) or angle (60°–90°) will handle the passenger vehicle (P) at slow (less than 10 mph) speeds.





## DRIVEWAY GRADE

### 4.1

#### IMPORTANCE OF DRIVEWAY GRADE

*Excessive driveway grade causes traffic to slow when vehicles enter and increases the chance of crashes.*

Driveway grade is important because turning vehicles must slow down to enter a driveway. The steeper the driveway, the greater the reduction in speed required to prevent hitting the bottom of the vehicle.

Vehicles entering and leaving driveways that have abrupt changes in grade must travel at extremely low speeds. For those entering the driveway, the possibility of rear-end collision on the public street is increased and following traffic must slow down for right turn vehicles. Exiting vehicles and those turning left into the driveway must wait for larger gaps in traffic.

Reducing driveway grade is an important consideration along roadways that carry considerable through traffic volumes. Steep driveways might be more acceptable on local streets and reconstruction/resurfacing projects. Steeper grades are also more acceptable at locations with low driveway traffic volumes where only a few trucks are expected to use the driveway.

## 4.2

### DRIVEWAY GRADE IN STANDARD INDEX 515

Guidelines for the driveway grades are included in ***Standard Index 515*** and **Chapter 12** of the ***Plans Preparation Manual (Right of Way)***. Maximum grades are 10% for commercial driveways and 28% for residential driveways. ***Standard Index 515*** (Sheet 6) gives guidance for various applications. An important note on Sheet 6 for Urban Turnout Profiles, states that in reconstruction projects, the 10% grade or less for commercial can be exceeded with the approval of the District Design Engineer where operational and safety impacts are acceptable.

If regular scheduled passenger buses will be using the driveway, the maximum grade should not normally exceed 12% with a preferred maximum design grade of about 8%.

*Source: Adapted from the Design Guide for Transit Facilities on Highways and Streets. AASHTO Phase I.*

Exhibit 24  
Acceptable Grades from  
Standard Index 515

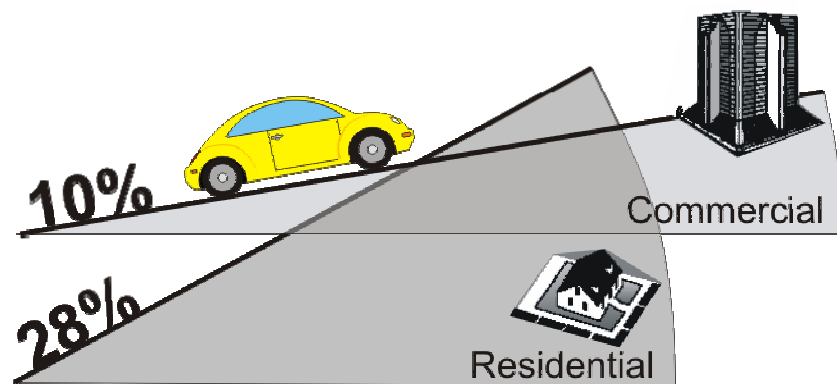

While these may be the maximum practical grades, it is much better to use smaller grades. **Research has shown that grades less than 14% for low volume driveways are more desirable and grades less than 5% for higher volume driveways are also more desirable.**

Even though the Standard Index uses the terms “Commercial” and “Residential”, you should also consider the expected traffic on the driveway. The amount and type of traffic for a barbershop (Commercial) is very different than a one million square foot mall (also commercial) or a 300 unit apartment complex (Residential). The barbershop, of course, would not need the design standards of either the mall or the apartment complex.



## Difference in Grade

The maximum practical **difference in grade is 12%**. Above these grades, vehicles will routinely “bottom out” and potentially cause damage to their vehicles. **This is called “A” or “Algebraic Difference in Grade” in Index 515 (sheet 6)**

*Source: Vergil Stover unpublished course notes*

## Super elevation and driveway visibility

Another concern in driveway grade is the visibility of the driveway. Sometimes a downgrade of a driveway, together with roadway super-elevation, especially on a horizontal curve, can lead to sight distance problems. Guidance for this concern is also found in *Standard Index 515 (Sheet 6)*.

### Exhibit 25 DRIVEWAY GRADE CROSS-SECTION

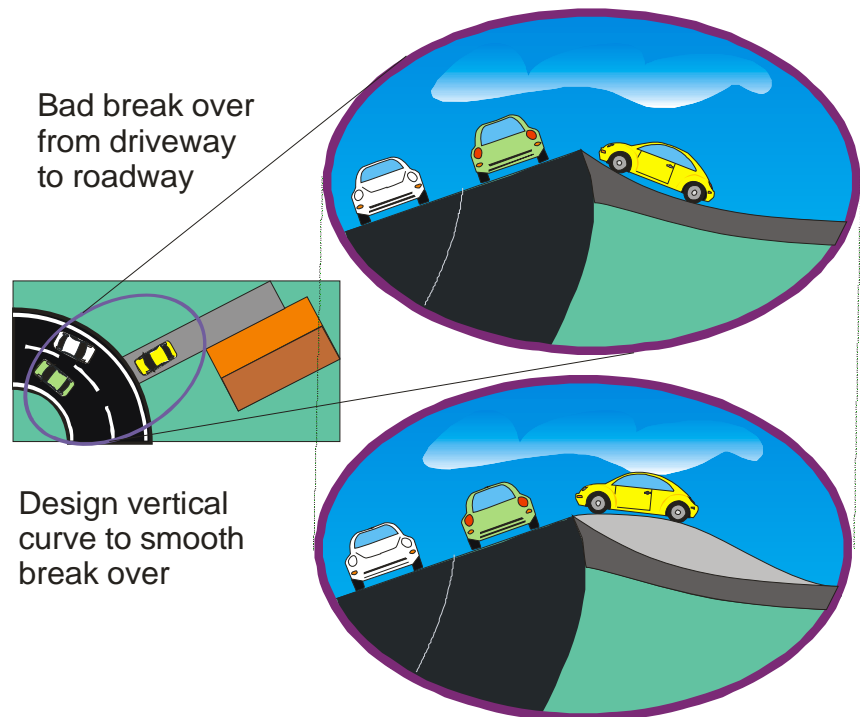

Exhibit 26  
*Standard Index 515 (Sheet 6)*  
 gives detailed information  
 and standards on grades and  
 difference in grades

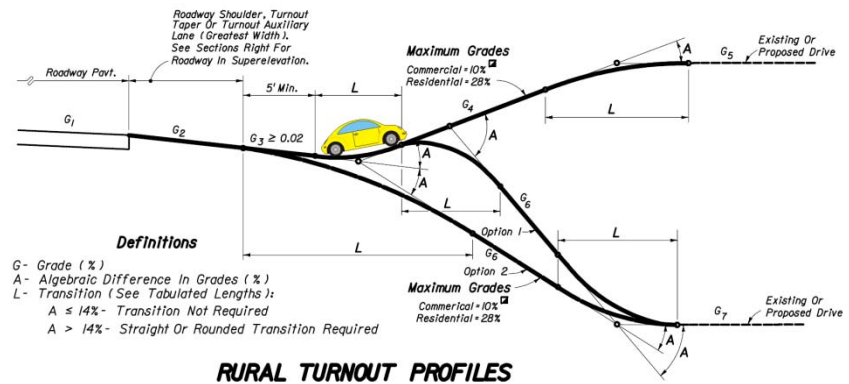
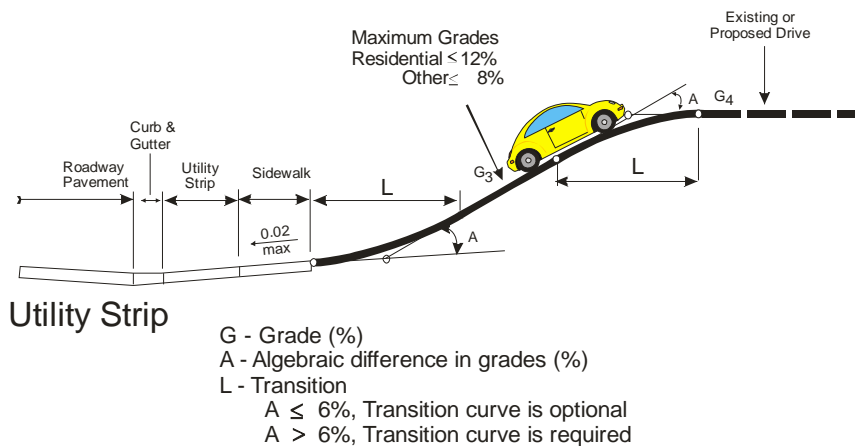

Exhibit 27  
 Adapted from *Standard Index 515 (Sheet 6)*



Guidance for Driveway Design During Design and Reconstruction in the Design Standards and in the Plans Preparation Manual (Curb and Gutter Sections)

**Standard Index 515** provides criteria and guidance for design of urban flared driveways.

Some guidance for urban driveway design is also shown in the **Plans Preparation Manual**, Chapter 12.2.2, Right of Way. The manual states the following:

“On projects with sidewalks and driveway connections, the design elements can be accurately established only if proper survey data has been obtained for the designer’s use. Profile elevations along the proposed R/W line and back of sidewalk and half-sections or profiles at each driveway location should be obtained as a minimum standard practice.”

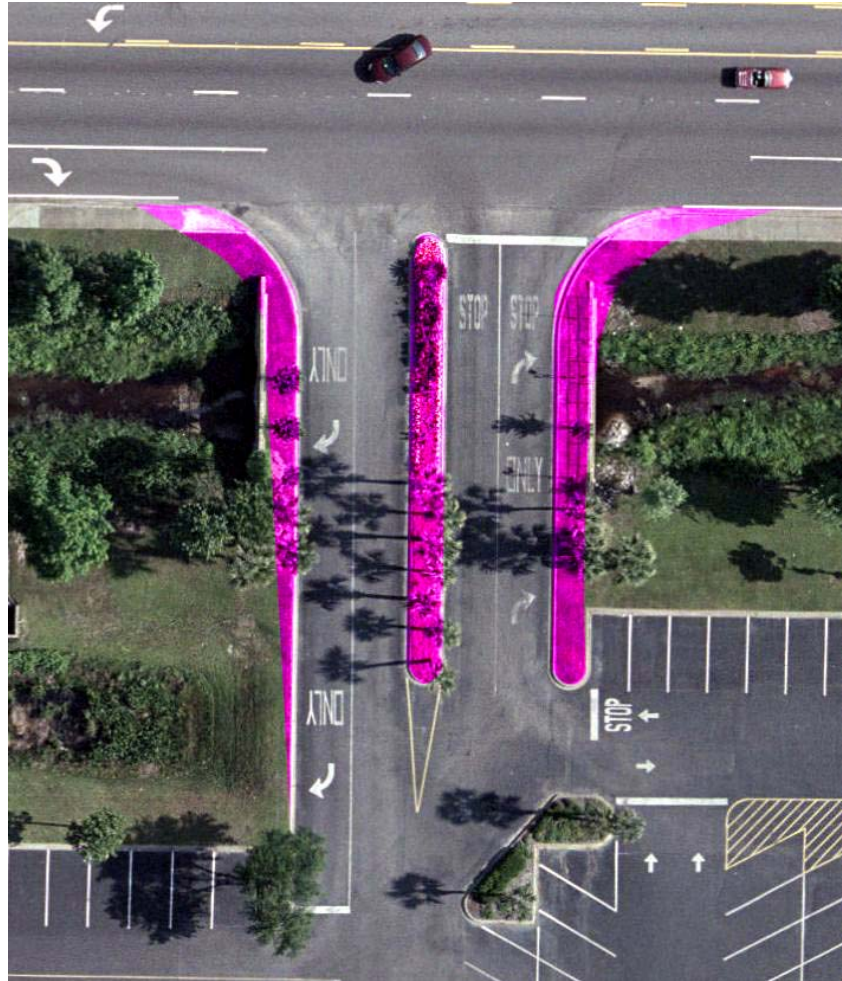

**DRIVEWAY CHANNELIZATION**

## 5.1

### CHANNELIZING DIVISIONAL ISLANDS

(Driveway Throat Medians  
or Traffic Separators)

Divisional islands are designed according to their main functions, such as:

- Pedestrian refuge islands
- Traffic separation
- Traffic flow separation.

A divisional island may serve a combination of these functions. It should be clearly visible at all times and located sufficiently in advance so that the vehicle operators will not be surprised. These islands should occupy the minimum amount of roadway space needed for the purpose and yet be large enough to be noticed.



When are divisional islands recommended?

Some of the disadvantages of divisional islands are they can become a hazard if they are not sized or placed correctly and pedestrians can trip over them.

At unsignalized driveways, right turn divisional islands should be used sparingly. Each channeling island adds to the width (thereby making the pedestrian cross more area), and it also may add confusion to drivers attempting to exit, as well as enter. Striping and well-marked exit lanes should handle most needs of unsignalized driveways.

---

You should consider divisional islands at driveways where:

- A large pavement area may confuse drivers.
  - Right in/right out driveways where movements may be unclear.
  - Traffic over 4,000 vehicles per day is expected.
  - The driveway is expected to have a signal in the future.
  - The driveway has 2 or more entrance lanes.
- 

## 5.2

### SIZE OF DIVISIONAL ISLANDS IN DRIVEWAY

Exhibit 28  
**DRIVEWAY  
 DIVISIONAL ISLAND  
 WIDTH**

Guidance on width not found in *Standard Index 515*

**Standard Index 515** calls these islands in driveways “**Divisional Islands**”, and the only guidance is on the width. The minimum in *Standard Index 515* is 4 feet and maximum is 22 feet. See Exhibit 28.

	Minimum	Maximum
Divisional Islands in Standard Index 515	4 feet	22 feet
(not part of Standard Index)	Recommended 6 feet	Recommended 16 Feet

Even though the maximum width specified in the **Standard Index 515** is 22 feet, a better design would be a maximum of 16 feet. This width is less confusing to the driver turning into the driveway. A wider island sometimes gives the driver the impression that there are two separate driveways.

Though sometimes necessary, a four foot width will not provide comfortable pedestrian refuge or good nighttime visibility.



Suggested Minimum Length

The minimum length of a non-triangular separator should be 40 feet. This helps visibility, especially at night.

*Source: Transportation and Land Development, 2nd Edition*

**Standard Index 302**, “Traffic Separators”, has important guidance on the cross sections, dimensions and construction of these separators.

Exhibit 29  
**CHANNELIZATION  
DESIGN TO SERVE  
TRUCK MOVEMENTS**

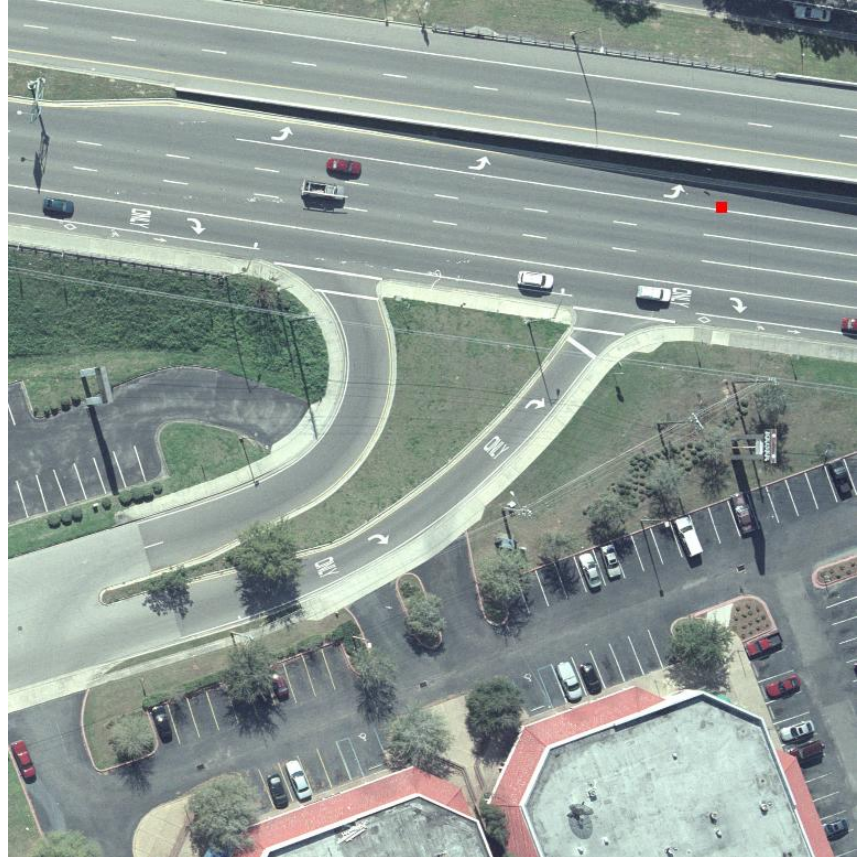

Pedestrian Considerations on Driveway Channelization

Traffic separators that may be used as pedestrian refuge islands should be at least 6 feet wide. Curb cuts for the disabled should allow access for people in wheelchairs to be able to access the refuge island. People in wheelchairs cannot safely take refuge in islands that are less than 5 feet wide. Side view mirrors on trucks can also encroach in the pedestrians' space.

## Triangular Islands

Exhibit 30  
Driveway “Pork-Chops”  
For Right Turns in and Out



**DON'T MAKE THE ISLAND TOO SMALL**

Exhibit 32  
“PORK CHOP” CLOSE TO AN INTERSECTION

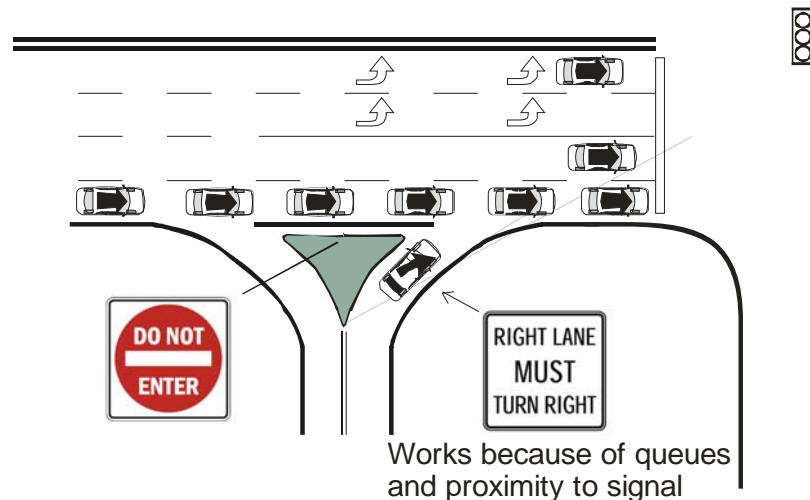

## Right Turn Out Channelization

In accordance with the *AASHTO Green Book (2004)*, Chapter 9, triangular curbed islands should be over 125 square feet with each side at least 15 feet in length.

Where there are no medians, avoid using driveway “pork chop” channelization to prevent left hand turns. These driveway channelization features, often called “pork chops”, can be a useful “message” to the driver where medians are in place to prevent left turns. Unfortunately, where these features are added to try and prevent left turns by themselves, they are usually failures. Observations of many of these show mixed results in compliance to their intended purpose. They, may in fact, prevent vehicles from quickly entering the driveway.

If the prohibition of left turns is desirable, the best way to do it is through the use of restrictive medians. Where median space is not available, the traffic engineer can consider flexible traffic posts in the main road to discourage left turns.

Pork chops can be useful on roadways with medians and the pork chop is only there to guide the driver to the allowed movement. The pork-chop design might also be useful on an undivided roadway where the driveway is so close to an intersection that the left turn would be unsafe at any time.

Where right turn exiting channelization is used, be careful to provide a traffic entry angle that is easy for the exiting driver to negotiate while trying to enter traffic. See Exhibit 31 that shows angles between 121-122°. This is the most comfortable angle for the entering driver.

Exhibit 31  
**TRAFFIC ENTRY ANGLE**

*For additional information on channelization, refer to: Intersection Channelization Design Guide (National Cooperative Highway Research Program Report No. 279) and Chapter 9 of the AASHTO Greenbook*

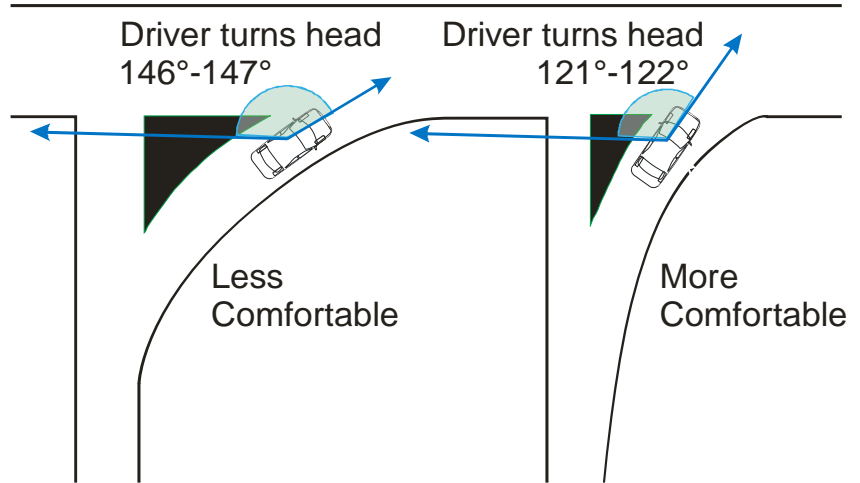

*Source: Michael Wallwork unpublished course notes*



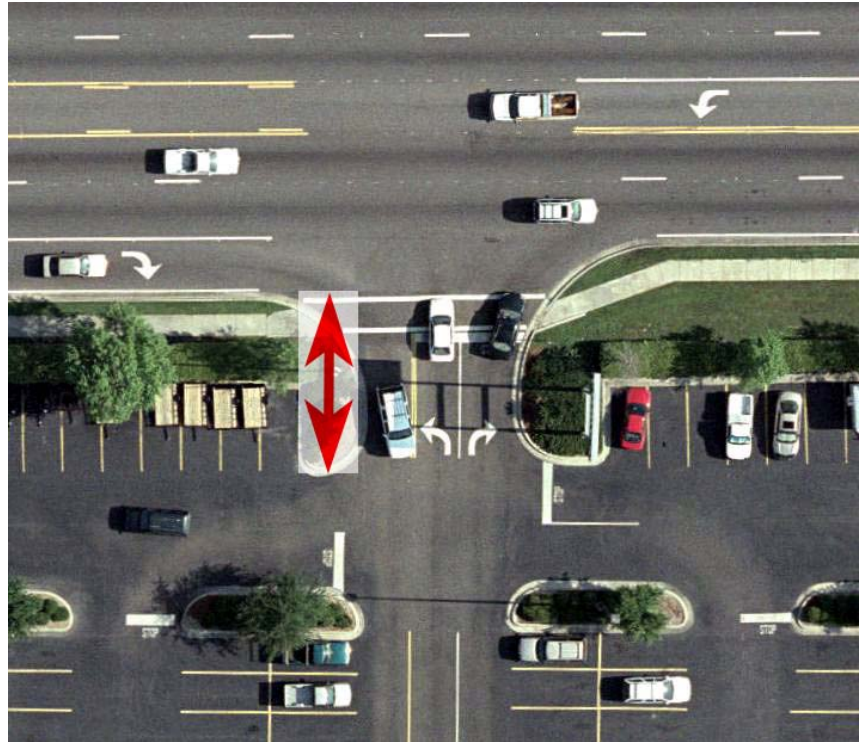

**DRIVEWAY LENGTH****6.1****INTRODUCTION**

Once a vehicle enters a driveway, the goal is to help guide the entering vehicle without disturbing traffic movement on site or on the main highway. An uninterrupted area (driveway length) before the first conflict point on site is an important tool for this. The greater the volume using the driveway, the more the driveway should be designed like a roadway intersection. Sufficient driveway length helps make the driveway operate more efficiently.

The following exhibits show the purpose of adequate driveway length. Note, that without proper driveway length, vehicles can experience multiple conflicts that can cause vehicles to become stuck in the through lanes of the main roadway.

**Exhibit 33  
INSUFFICIENT  
DRIVEWAY LENGTH**

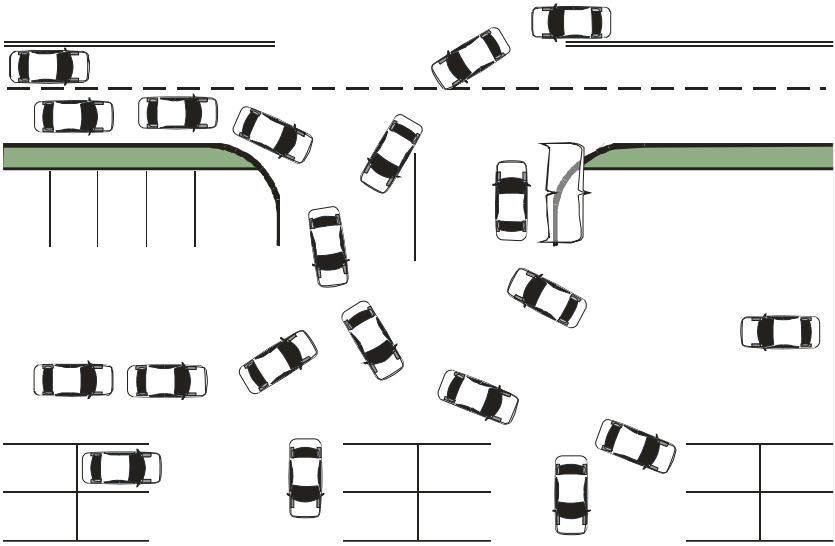

**Exhibit 34  
SUFFICIENT  
DRIVEWAY LENGTH**

*“Driveway length” is from edge of traveled way to the first conflict point*

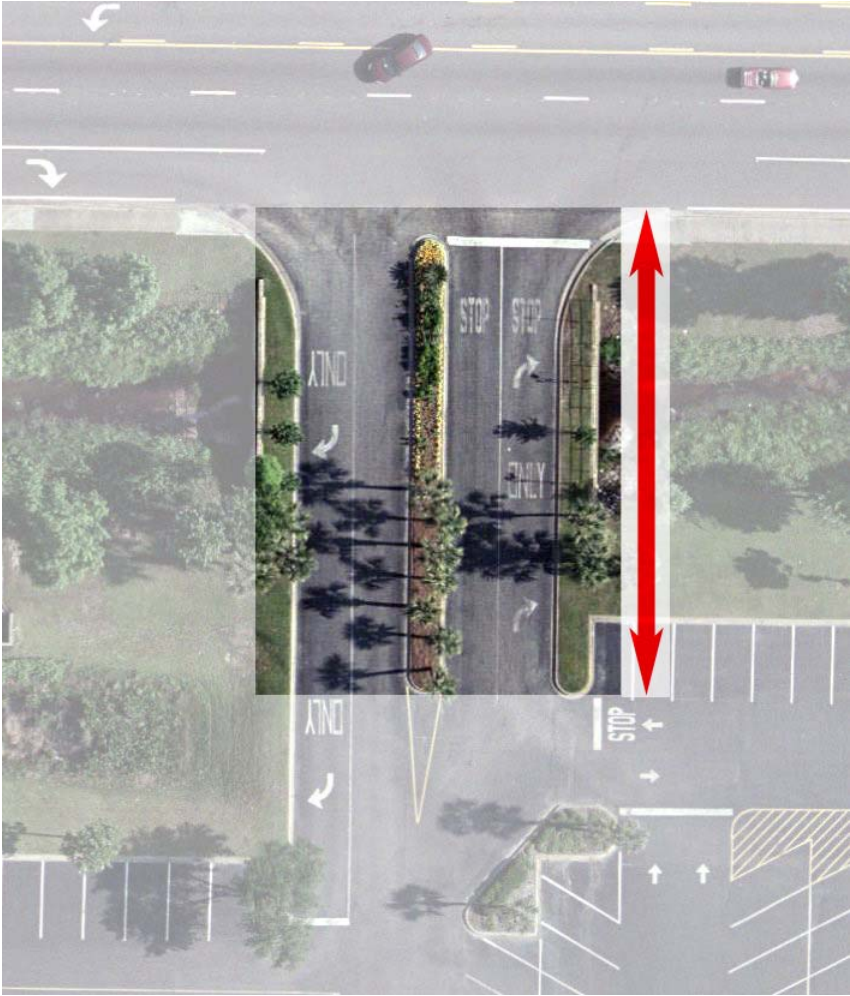

### **Note for driveways impacted during roadway improvements**

For corridor improvements (not during the driveway permit process) the ability to design adequate driveway length may depend on existing development and available right of way. Where the land use along the corridor is dense you might be restricted to the amount of driveway length you can redesign at individual locations. Working with the property owner for a better design on their property will benefit the driver as well as the business. You might need to work in coordination with the local government where landscaping or parking spaces are impacted.

## 6.2

### **SOME GUIDANCE FROM STANDARD INDEX 515**

The *Standard Index 515* – Sheet 1 – *General Note 5* states that the driveway design (including length) needs to be determined by the desired operation of that driveway.

---

**Driveways shall have sufficient length and size for all vehicular queuing, stacking, maneuvering, standing, and parking to be carried out completely beyond the right of way line.** Except for the vehicles stopping to enter the highway, the turnout areas and drives within the right of way shall be used only for moving vehicles entering or leaving the highway.

*Source: Standard Index 515 – Note 5*

---

### Setback from Right of Way Line to Structure

In *Standard Index 515* (Sheet 1) Setback (**G**) to a structure is a measure from the right of way line to the structure. See Exhibit 35. The minimum distance is 12 feet. This standard was developed with low volume and passenger car usage in mind. *General Note 5* will be a more important criterion. This note states the setback (as well as all internal circulation elements) should be designed to provide for smooth and safe operations on the driveway and surrounding road system. Therefore, you will probably need more than 12 feet setback for most commercial uses.

Exhibit 35  
**SETBACK**

Adapted from *Standard Index 515*

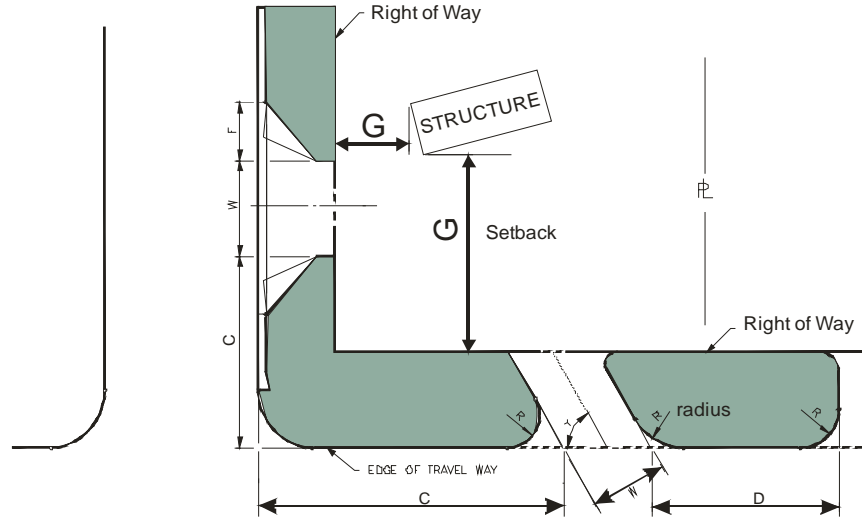

**G = 12 feet or greater, however it needs to be placed so “all vehicular queuing, stacking, maneuvering, standing, and parking to be carried out completely beyond the right of way line”**

*Source: Adapted from Standard Index 515 (Sheet 1)*

Determining the Best  
Driveway Length

Major driveways to large developments should be designed as roadway intersections and not just a simple driveway. This type of access will have multiple lanes and sufficient positive guidance to the driver.

For driveways that may be signalized, driveway length should be determined by a traffic study of expected future traffic and queues. An important measurement in determining the driveway length is the outbound queue.

For unsignalized driveways, or for a first estimate of driveway length, you can use the estimates in Exhibit 36.

Exhibit 36  
Recommended Minimum  
Driveway Length for Major  
Entrances

**Note:** for large developments (such as regional malls, big box centers, or regional office centers), the total recommended length is not necessary for all entrances, only the major ones.

Land Use	Driveway Length (In feet)
Any major entrance to a development with 4 or more total lanes in the driveway. (typically malls and “Big Box Centers” )	300 or greater, based on traffic study
Regional Shopping Centers (over 150,000 sq. ft.)	250
Community Shopping Center (100-150,000 sq. ft.) (supermarket, drug store, etc.)	150
Small Strip Shopping Center	50
Smaller Commercial Developments (convenience store with gas pumps)	30

*Source: Adapted from Vergil Stover unpublished course notes*

Older Developments on  
Small Sites

Where a site is being redeveloped on a small property with no reasonable alternative access, it may be difficult to get these driveway lengths. In these cases, position the driveway to take advantage of the on-site location with the most depth.

Exhibit 37  
**DO THE BEST YOU CAN**





## 6.3

### DRIVEWAY LENGTH AND PARKING MOVEMENTS

Inadequate driveway length can also produce hazards to entering traffic on site. Particularly where the on-site parking can back out of and block the driveway and prevent a vehicle from entering. To avoid this problem, a distance of at least 50 feet should be used on driveway length where back out parking may interfere with the entry movement.

**Exhibit 38**  
**Parking Lots And Internal Circulation**  
*In this case the backing auto conflicts with the entering auto*

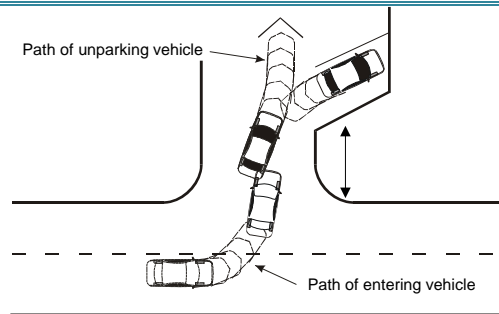

**Exhibit 39**  
*50 feet allows one vehicle to enter before a conflict with the sidewalk*

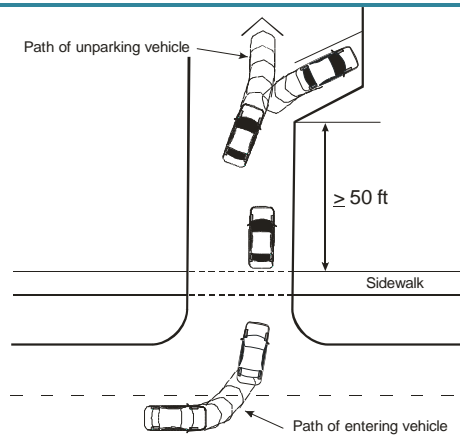

**Exhibit 40**  
**MOST PREFERRED DESIGN**  
*Where right of way exists, you can design the driveway where the driver completes the left-turn entry maneuver, clears the through traffic lane and then stops before coming to the sidewalk when a pedestrian is present*

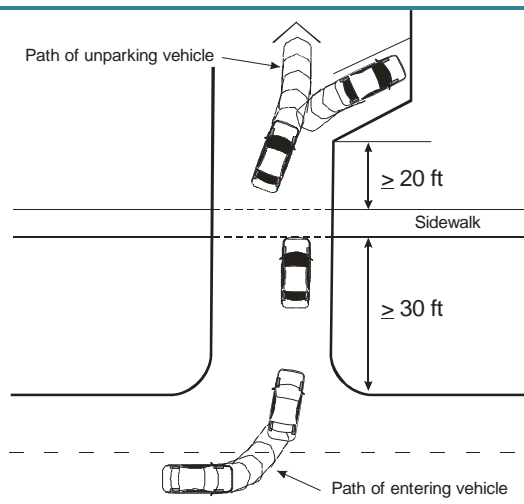

*Source: Transportation and Land Development, 2002, Stover*

Residential Garage and Carport Turn-Arounds

Exhibit 41  
**CARPORT TURN-AROUNDS**

Driveways should not force vehicles to back out directly into arterial roadways. Constructing garage and carport turnarounds is one way to accommodate the exiting vehicle.

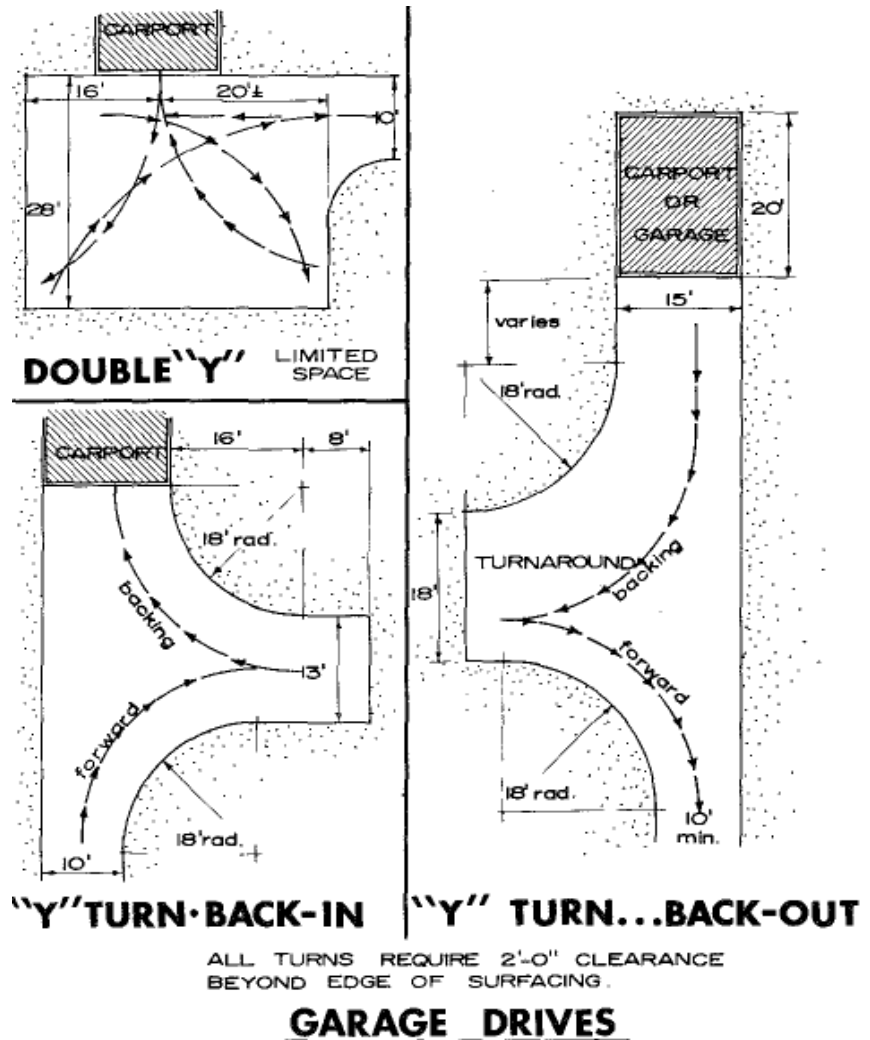

Source: Joseph DeChiara & Lee Koppelman "Urban Planning and Design Criteria" Van Nostrand Reinhold, 1982

## 6.4

### DRIVE THROUGH QUEUES



Exhibit 42  
**RECOMMENDED DRIVE THROUGH QUEUES**

In determining on-site design, including driveway length, knowledge of the expected queue of drive through traffic is important. These queues should be stored away from the area of the driveway used for driveway length.

Larger site sizes for modern service stations, convenience markets and the stand alone drug stores with drive through prescription service has helped assure that these distances are provided for newer development.

If a queuing study is not done to determine the appropriate length, the following table provides a reasonable estimate.

These distances are based on the Passenger Vehicle (P-Vehicle) at 25 feet per queued vehicle.

Use	Maximum Observed Queue	Queue Distance Required (Based on 25 feet per queued car)
Fast-Food (hamburger)	9	225 ft.
Bank	7	175 ft.
Car Wash (self-service)	2	50 ft.
Day Care	9	225 ft.
Dry Cleaner	2	50 ft.
Drive-Through Stand-Alone Drug Store	4 (Estimated) <i>See Note below</i>	100 ft. (Estimated) <i>See Note below</i>

*Adapted from the Source: James Gattis, "Queuing Areas for Drive Through Facilities, ITE Journal, May 1995.*

**Note:** Though no known comprehensive studies exist now, drug store prescription drive-through locations should provide sufficient queue length for 4 vehicles (or 100 ft.).





### **A Special Note on School Sites**

Schools served by school buses pose a particular challenge to the design with sufficient queue areas that don't conflict with movements on the highway system. The size of school buses, as well as the peaking characteristics from parent pick-up combines to make it a challenge. You might need to work closely with school officials to assure that back-ups on the State Highway System are avoided. A queuing study might be necessary in order to assure this.

See Exhibit below from a school bus queuing study

Table 3 – Calculated Maximum Queues

<i><b>Movement</b></i>	<i><b>Critical Hour</b></i>	<i><b>AppVol</b></i>	<i><b>ConfVol</b></i>	<i><b>Maximum Queue</b></i>
<i>Ponkan Road Left-In at Staff/Parent/Student Driveway (Major Street Left Turn)</i>	AM Peak	261	1340	8
	PM Peak	78	872	3
<i>Ponkan Road Left-In at School Bus Driveway (Major Street Left Turn)</i>	AM Peak	20	1357	1
	PM Peak	20	889	1
<i>Staff/Parent/Student Driveway Left-Out (Minor Street Left Turn)</i>	AM Peak	198	1916	10
	PM Peak	322	1285	14
<i>Staff/Parent/Student Driveway Right-Out (Minor Street Right Turn)</i>	AM Peak	107	427	3
	PM Peak	174	364	5
<i>School Bus Driveway Left-Out (Minor Street Left Turn)</i>	AM Peak	37	2079	3
	PM Peak	37	1445	3
<i>School Bus Driveway Right-Out (Minor Street Left Turn)</i>	AM Peak	20	660	2
	PM Peak	20	426	2

*Source: Apopka High School Relief Traffic Study – Orange County (Florida) School Board 2004*





## RIGHT TURN LANES

### 7.1

#### EXCLUSIVE RIGHT TURN LANES AT UNSIGNALIZED DRIVEWAYS

Exclusive right turn lanes are useful where a combination of high roadway speeds, and high right turn volumes into a driveway are expected. Congestion on the roadway may also be a good reason to use an exclusive right turn lane. If properly built, they remove the turning vehicle from the through lanes, thereby decreasing the operational impact of right turn vehicles on the through traffic.

The *Standard Index* has no specific guidance on warrants for right turn lanes into unsignalized driveways. These guidelines were developed to assist in the decision-making. However, *Standard Index 301* contains the standards necessary for the design of right turn lanes. The picture in Index 301 shows a left turn lane, but the design features are the same, except for the fact that queues would not usually be present on unsignalized driveways.

## 7.2

### WHEN SHOULD WE BUILD RIGHT TURN LANES?

Exhibit 44  
**RECOMMENDED  
GUIDELINES FOR  
EXCLUSIVE RIGHT  
TURN LANES TO  
UNSIGNALIZED\*  
DRIVEWAY**

Roadway Posted Speed Limit	Number of Right Turns Per Hour
45 mph or less	<b>80-125</b> (see note 1)
Over 45 mph	<b>35-55</b> (see note 2)

\*May not be appropriate for signalized locations where signal phasing plays an important role in determining the need for right turn lanes.

1. The lower threshold of 80 right turn vehicles per hour would be most used for higher volume (greater than 600 vehicles per hour, per lane in one direction on the major roadway) or two-lane roads where lateral movement is restricted. The 125 right turn vehicles per hour upper threshold would be most appropriate on lower volume roadways, multilane highways, or driveways with a large entry radius (50 feet or greater).
2. The lower threshold of 35 right turn vehicles per hour would be most appropriately used on higher volume two-lane roadways where lateral movement is restricted. The 55 right turn vehicles per hour upper threshold would be most appropriate on lower volume roadways, multilane highways, or driveways with large entry radius (50 feet or greater).

**Note:** A posted speed limit of 45 mph may be used with these thresholds if the operating speeds are known to be over 45 mph during the time of peak right turn demand.

**Note on Traffic projections:** Projecting turning volumes is, at best, a knowledgeable estimate. Keep this in mind especially if the projections of right turns are close to meeting the guidelines. In that case you may want to require the turn lane.

## Where The Right Turn Lane Guidelines Came From

These recommendations are primarily based on the research done in *NCHRP Report 420 Impacts of Access Management Techniques*, Chapter 4 – Unsignalized Access Spacing (Technique 1B), and *Use of Speed Differential as a Measure To Evaluate the Need for Right-Turn Deceleration Lane at Unsignalized Intersections*, by Jan Thakkar, P.E., and Mohammed A. Hadi, Ph.D., P.E.

In the *NCHRP Report 420*, the observed high-speed roads, 30 to 40 right turn vehicles per hour caused evasive maneuvers on 5 to 10 percent of the following through vehicles. For lower speed roadways, 80 to 110 right turn vehicles caused 15 to 20 percent of the following through vehicles to make evasive maneuvers. The choice of acceptable percentages of through vehicles impacted is a decision based on reasonable expectations of the different roadways.

In the Thakkar-Hadi study, by modeling speed differentials, a better understanding of the impacts of through volume and driveway radius was discovered.

### 7.3

#### IMPACT OF LARGE AND SLOW MOVING VEHICLES TURNING RIGHT



Speed and the volume of right turns should not be the only criteria used to determine the requirement for an exclusive right turn lane at unsignalized intersections. In order to minimize the rear-end collision potential of some situations, a right turn lane may be required where large and slow moving vehicles need to turn right such as;

- Trucking facilities (or locations that have a high volume of large vehicle traffic such as water ports, train stations, etc.)
- Recreational facilities attracting boats, trailers and other large recreation vehicles
- Transit facilities
- Schools

## 7.4

### REQUIRING RIGHT TURN LANES OUTSIDE THESE GUIDELINES

Consider Adding Right Turn Lane

**Conditions for providing an exclusive right turn lane** when the right turn traffic volume projections don't exceed the guidelines:

- Facilities having a high volume of buses, trucks or trailers (2 or 3 per hour) *See Chapter 2* for “**Designing for Trucks and Other Large Vehicles**”
- Poor internal site design of a driveway facility causing potential backups in the through lanes (*See Section 6.1*) on “**Driveway Length**” regarding concerns on-site conflicts)
- Heavier than normal peak flows on the main roadway
- Very high operating speeds (such as 55 mph or above) and in rural locations where turns are not expected by through drivers
- Highways with curves or hills where sight distance is impacted
- Gated entrances
- Crash experience, especially rear end collisions.
- Intersections or driveways just after signalized intersections where acceleration or driver expectancy would make a separate right turn lane desirable (this would also be the case downstream soon after a dual left turn lane onto a four lane road)
- Severe skewed angle of intersection requiring right turn vehicle to slow greatly.

**Conditions for not requiring a right turn lane** where the right turn volumes might exceed the guidelines:

- Dense or built out corridor where space may be limited
- Where a right turn lane would significantly impact pedestrians or cyclists
- Where sufficient distance from neighboring driveways or streets is not available for the appropriate design

Consider Not Adding Right Turn Lane

## 7.5

### HOW SHOULD THE EXCLUSIVE RIGHT TURN LANES BE DESIGNED?

According to Florida Department of Transportation ***Standard Index 301***, on Turn Lanes, both right and left turn lanes need to be constructed with the appropriate taper, deceleration and queue lengths. Unsignalized right turn lanes would normally not have queues. Therefore, the right turn lane would only consist of taper and deceleration to the stop condition. ***Standard Index 301***, General Notes, # 2 and 3 state:

2. Total deceleration distances must not be reduced except where lesser values are imposed by unmovable control points.
3. Right turn lane tapers and distances are identical to left turn lanes under stop conditions.

See Chapter 10 Striping for exclusive right-turn lanes with bicycle lanes for more detail on striping right-turn lanes and bike lanes.

#### Control Zones for Right Turn Lanes

Please refer to the most current ***Plans Preparation Manual*** (Volume I, Chapter 2.11) for information on horizontal clearance and ***Utility Accommodation Manual*** (Chapter 9) for the treatment of control zones for right turn lanes.







## SIGHT DISTANCE AT DRIVEWAYS

### 8.1

#### SIGHT DISTANCE AT DRIVEWAYS

##### Sight Distance Concepts

This section addresses sight distance issues related to unsignalized driveways. Much of this chapter contains discussion of the assumptions relating to stopping and intersection sight distances. This discussion is included to provide background for the suggested/recommended sight distances that are included in this chapter. Passing and decision sight distances are not addressed here because they are not normally an element in driveway location and design.

Driveways must be located to provide sufficient sight distance so that drivers can safely operate their vehicles. The following concepts and definitions are important in the correct use of sight distance.

Exhibit 45  
SIGHT DISTANCE

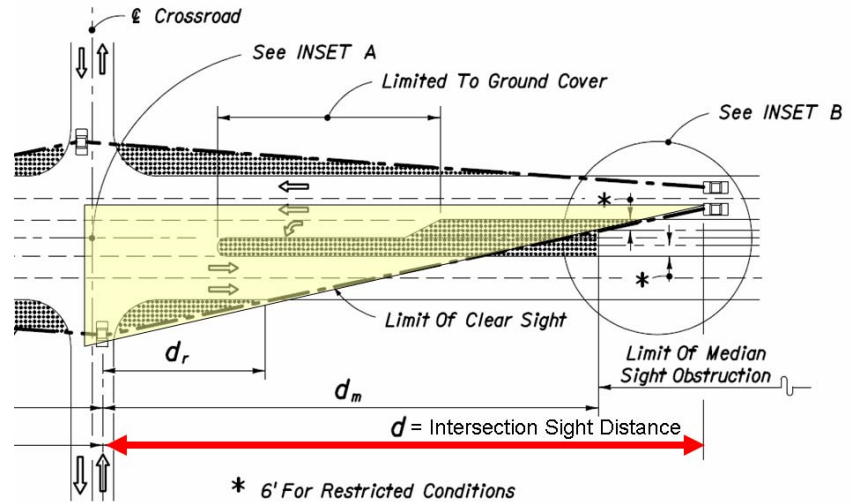

From Standard Index 546 (Sheet 6)

Stopping Sight Distance: The distance necessary for the driver to safely bring a vehicle to a stop to avoid a hazard in the roadway. Guidance on Stopping Sight Distance is found in the **Plans Preparation Manual**, Section 2.7.

Intersection Sight Distance: The distance necessary for drivers to safely approach, cross, and/or turn right or left at an intersection. Intersection sight distance varies, depending on the design speed of the roadway to be entered, and assumes a passenger car can turn right or left without being overtaken by an approaching vehicle. Guidance on Intersection Sight Distance is found in **Standard Index 546**.

**Further discussion of the important concept of Intersection Sight Distance is in Section 8.3**

Exhibit 46  
HOW SIGHT DISTANCE (SD) IS MEASURED AND DRIVER EYE SETBACK

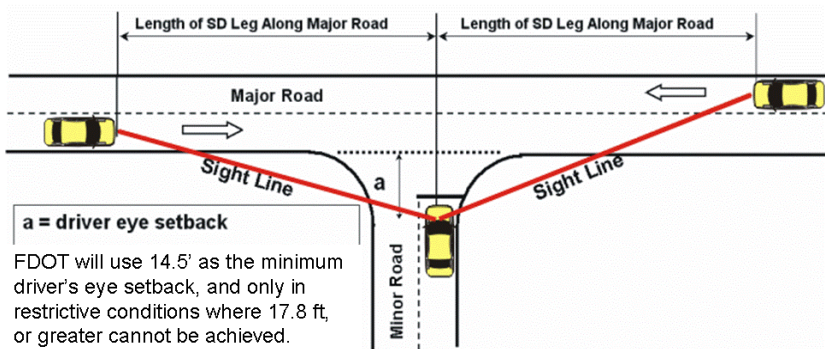

**Note:** FDOT will use 14.5' as the minimum driver's eye setback, and only in restrictive conditions where 17.8 ft, or greater cannot be achieved.

Changes Between the 1990 and 2001 AASHTO Green Books:

Changes to some of the assumptions in sight distance calculations have caused significant changes in the intersection sight distances.

The intersection sight distances for passenger vehicles (P) found in the **AASHTO Green Book** may be used in restrictive circumstances. In order to provide a greater margin of safety, you may want to use the **AASHTO Green Book** measures for the Single Unit (SU) vehicle rather than the Passenger (P) vehicle for minimum sight distances. The SU vehicle is a typical delivery truck that serves most businesses on a daily basis.

## 8.2

### STOPPING SIGHT DISTANCE (SSD)

Sight distance is the length of roadway ahead visible to the driver. The minimum sight distance available on a roadway should be sufficient to enable a vehicle traveling at the design speed to stop before reaching a stationary object in its path. The sight distance should be at least that required for a vehicle on the main roadway to stop for a hazard at a cross-street. The following stopping sight distances are from the **Plans Preparation Manual**

Exhibit 47  
**Stopping Sight Distance  
For New Construction  
From Plans Preparation  
Manual**

Design Speed (mph)	New Construction Distance in Feet
35	250
40	305
45	360
50	425
55	495
60	570

*Source: Plans Preparation Manual Table 2.7.1 (for arterials of grades of 2% or less). These distances will be greater on downhill sections and will be less for Resurfacing and Rehabilitation projects. See the Plans Preparation Manual for more details.*

### 8.3

## INTERSECTION SIGHT DISTANCE

Intersection sight distance is the most appropriate criteria for driveway operations since this allows the drivers both on the driveway and the roadway to adjust speeds and position to merge into traffic rather than requiring someone to make an emergency stop.

*Intersection sight distance for right and left turns on all roads.*

The **Standard Index 546** specifies the following intersection sight distances for right and left turns at intersections on multi-lane roads with medians.

**Exhibit 49  
Intersection Sight  
Distance with Clear Sight  
Triangle**

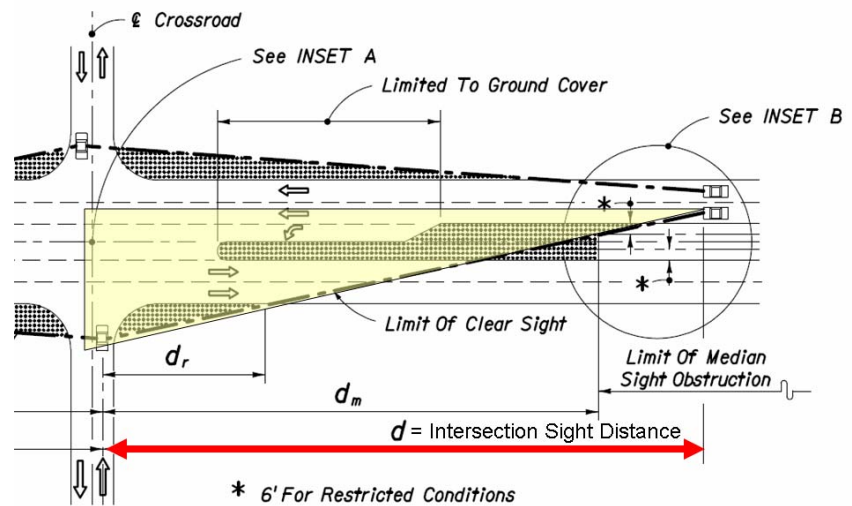

*From Standard Index 546 Sheet 4*

**Exhibit 50  
INTERSECTION SIGHT  
DISTANCE FOR  
FOUR LANE DIVIDED  
ROADWAYS**

Design Speed (mph)	Sight Distance at Intersection (in feet) Passenger Vehicle (P) (feet)	Sight Distance at Intersection (in feet) Single Unit Vehicle (SU) Common Delivery Truck (feet)
35	460	630
40	520	720
45	590	810
50	650	900
55	720	990
60	780	1,080

*Source: Standard Index 546 – for 4-lane with a 22' (or less) median width (sheet 4)*

The **Standard Index 546** contains more detail on wider medians, 2 lane roadways, 6 lane roadways, and for Intermediate Semi-Trailers (WB-40 and WB-50).

When Intersection Sight Distance Cannot Be Met

If sufficient intersection sight distance cannot be achieved, and there are no other driveway location alternatives, stopping sight distance can be used. This distance will allow the through traffic driver to avoid a hazard at the driveway.

**The Crossing Maneuver as a Two Step Process**

Also, if full intersection sight distance cannot be achieved on a driveway connecting to a multi-lane highway, and the median is sufficiently wide (minimum 25' for a passenger vehicle), the maneuver may be performed as two operations. The stopped vehicle must first have adequate sight distance to depart from a stopped position and cross traffic approaching from the left. The crossing vehicle may then stop in the median prior to performing the second operation. The second move requires the necessary sight distance for vehicles to depart from the median opening, to turn left into the cross road, and to accelerate without being overtaken by vehicles approaching from the right. Exhibit 51 shows the FDOT criteria for this movement.

Intersection Sight Distance for Six Lane Divided Roadways where Left Turns Can be Made as a 2-Step Maneuver

Exhibit 51  
**Intersection Sight Distance For 6 Lane Divided Roadways With Wide Medians That Can Protect Left Turning Vehicles**

Design Speed (mph)	Sight Distance at Intersection (in feet) Passenger Vehicle (P) Median width over 25'	Sight Distance at Intersection (in feet) Single Unit Vehicle (SU) Median width over 40'
35	360	470
40	410	540
45	460	610
50	510	680
55	570	740
60	620	810

*Source: Standard Index 546 (sheet-5) – for 6-lane*

The **Standard Index** 546 contains more detail on wider medians, 2 lane roadways, 6 lane roadways, and for Intermediate Semi-Trailers (WB-40 and WB-50).

## 8.4

### SIGHT DISTANCE AND LANDSCAPING

Two important Florida Department of Transportation documents address landscaping as they relate to access management:

***Standard Index 546*** (Sight Distance at Intersections)  
***Florida Highway Landscaping Guide*** (FDOT, Environmental Management Office 1995)

Exhibit 52  
**Stopping Sight Distance**

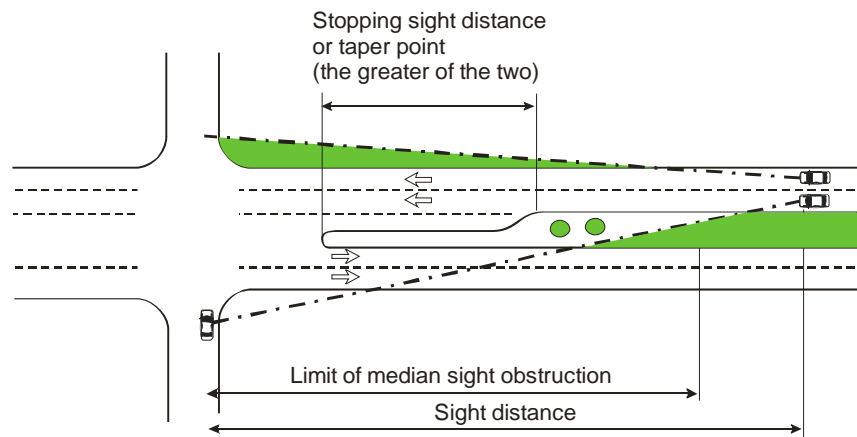

Source: Adapted from *Standard Index 546 (Sight Distance at Intersections)*

The ***Florida Highway Landscaping Guide*** states the importance of access management in providing good visibility and landscaping opportunities:

“A well-designed highway with good access management can be aesthetically pleasing. It provides the landscape architect greater opportunity in the development of practical and efficient landscape plans. When the number of median openings and driveway connections are reduced, a greater area is generally available for landscaping.

Source: *Florida Highway Landscaping Guide, FDOT – Environmental Management Office (1995)*



## 8.5

### CRITERIA FOR DECISIONS ON SIGHT DISTANCE AND LANDSCAPING NEAR DRIVEWAYS AND IN THE MEDIAN

- Sight Distance** - For right and left turns as stated in the Standard Index 546
- Stopping Sight Distance** - For absolute minimum clear area
- Tree Caliper** - 4 inches or less preferred measured 6 inches above ground
- Tree Spacing in Median** - As stated in the Standard Index 546
- Area Size of Vehicle Seen** - 50% of the vehicle on the roadway should be visible or there should be 2 seconds of complete unobstructed visibility
- Clear Sight Window** - Criteria – see Exhibit 53 “Clear Sight Window”

Exhibit 53  
**CLEAR SIGHT WINDOW**

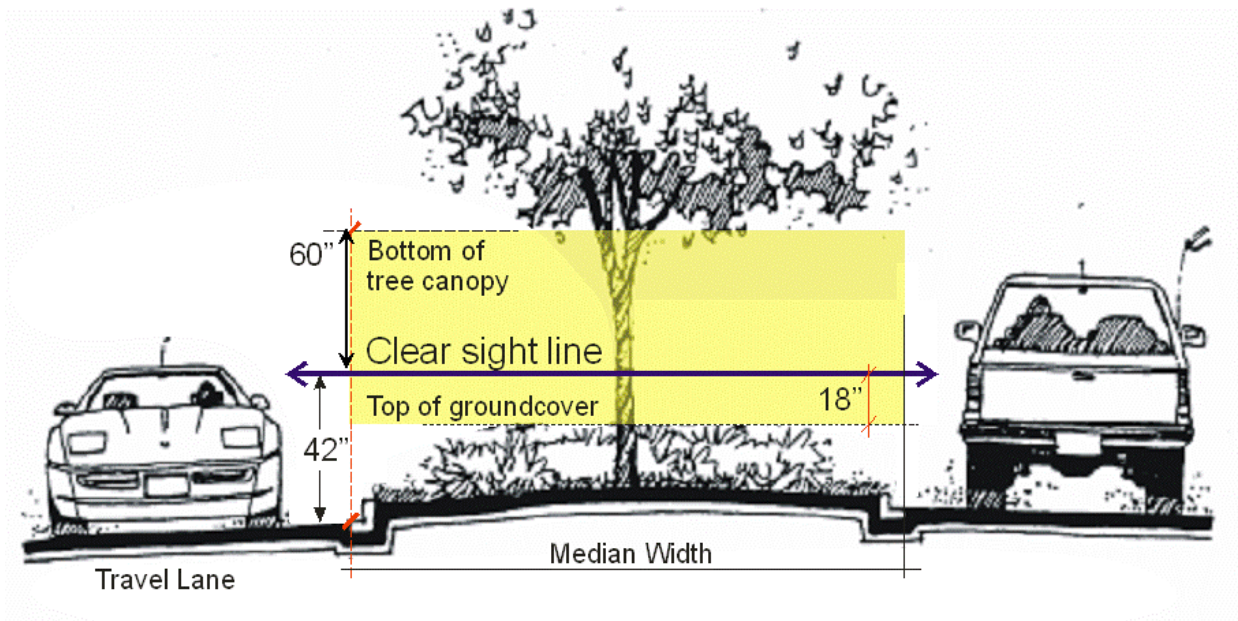
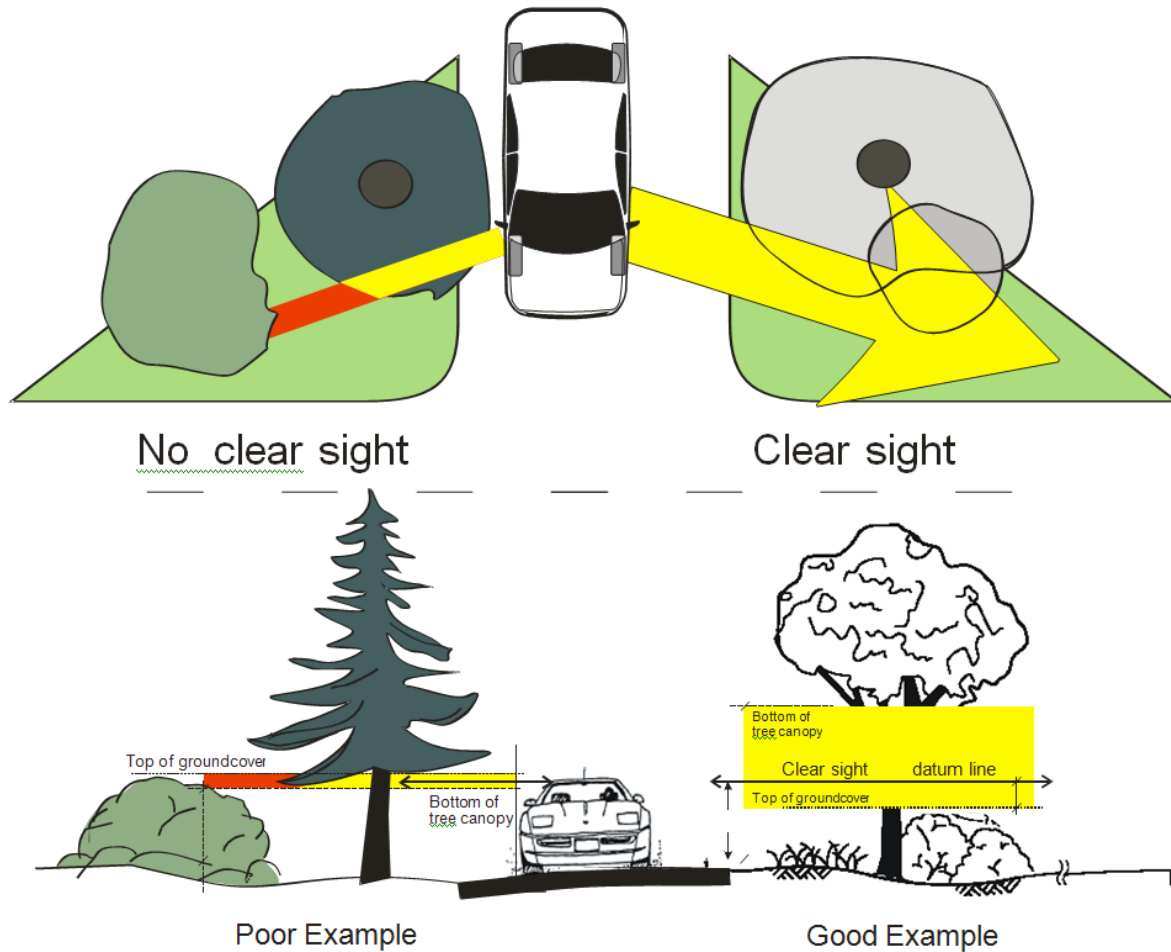

Exhibit 54  
**POOR SIGHT DISTANCE**



*The intent of this standard is to provide a window with vertical limits of not less than 5' above and 18" below the sight line datum, and horizontal limits defined by the limits of clear sight.*  
 Source: Standard Index 546

The same standards are desired for both signalized and unsignalized intersections because:

- Signals can malfunction
- Signals can go to flashing mode

The most critical landscape controls will be on the sight triangle and the portion of the median with potential to block a driver's view. The tree Spacing Standards are found in **Standard Index 546** for trees up to 11" in diameter and those over 11" but less than 18" (Sabal Palms – the State Tree). The bottom of the tree canopy should be greater than 8.5 feet or greater and the top of ground cover should be not taller than 1.5 feet below the average eye level (also called the Clear Sight Datum Line).



## 8.6

### SIGHT DISTANCE AND ON-STREET PARKING

Exhibit 54  
**UPSTREAM AND  
 DOWNSTREAM SIGHT  
 DISTANCE**

Location of a driveway close to on-street parking can seriously impact visibility. This situation is most common on roadways in dense developed areas. **Standard Index 17346 (Sheet 10)** contains the guidance on the placement of driveways in relation to on-street parking.

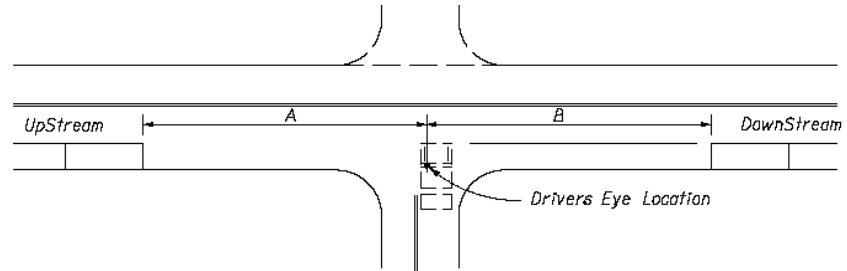

Speed MPH	Upstream (A)	Downstream (B)	
		2 Lane	4 Lane
0-30	85 ft	60 ft	45 ft
35	100 ft	70 ft	50 ft

*Notes:*

1. Distances measured longitudinally along the street from driver location of entering vehicle to end of parking restriction.
2. Distances applicable to intersecting street, major driveways and other driveways to extent practical.
3. For non-signalized intersections, the values above shall be compared with the values for signalized intersections and the maximum restrictions implemented. These restrictions apply to both accessible and non-accessible parking.

Source: Standard Index 17346 Sheet 10

## 8.7

### SIGHT DISTANCE DURING CONSTRUCTION

It is important to coordinate with whatever state, or local government in charge of roadway or building construction in the area of the driveway to assure that the placement of barriers around the site does not complicate or compromise the sight distance for the driveway.



**DRIVEWAY LOCATION**

## 9.1

### DRIVEWAY LOCATION

Driveways don't operate in isolation. Their operations are impacted by traffic on the roadway, as well as neighboring traffic features. Because of this, it is important to consider the location of driveways in relation to the distance to:

- Neighboring streets
- Signalized intersections
- Neighboring driveways
- Median openings
- Freeway interchange ramps
- Bus stops.

The way to measure distance between driveways and neighboring streets is defined in **Administrative Rule Chapter 14-97** and shown in **Standard Index 515**. See Exhibit 56.

Notice how it's measured from the two closest edges of the driveway (or its projected edge line at the edge of travel way). You can see how this is done in the following diagrams.

Exhibit 56  
**DRIVEWAY LOCATION**

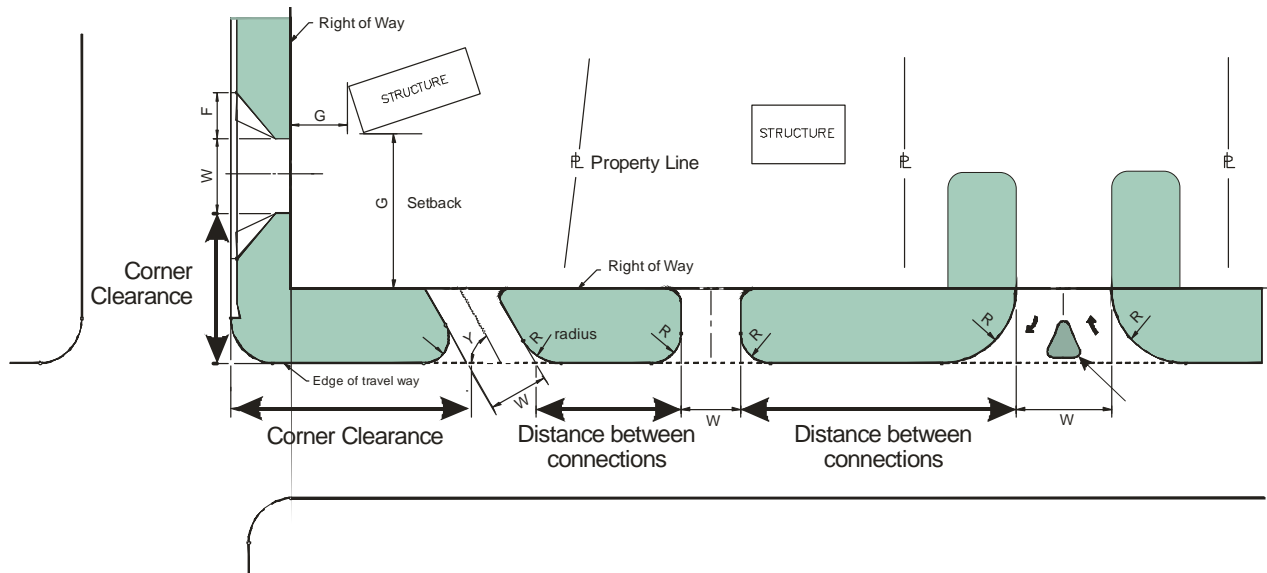

Source: Adapted from Standard Index 515

## 9.2

### DRIVEWAYS NEAR INTERSECTIONS (CORNER CLEARANCE)

Driveways and median openings close to a major intersection create a situation where the driver must negotiate conflicts close to an area that has been designed to manage large volumes of traffic. This situation can lead to poor safety and operational conditions. Proper driveway placement can help alleviate this problem. Proper driveway placement can also help the business operators, because traffic queues can become so long that traffic exiting driveways may be blocked for long periods of time.

Exhibit 57  
CORNER CLEARANCE

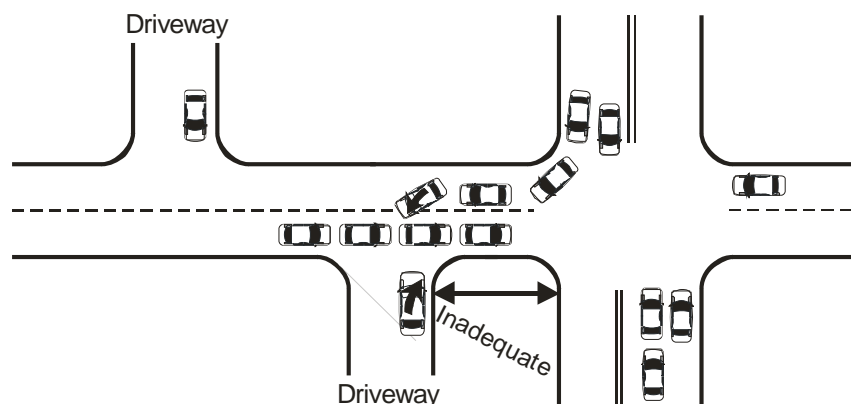

The **AASHTO Green Book** cautions us on driveways placed too close to intersections says,

“ ... driveways should not be located within the functional area or influence area of an adjacent driveway. The functional area extends both upstream and downstream from the physical intersection area and includes the longitudinal limits of auxiliary lanes”

*(AASHTO Green Book)*

## 9.3

### OTHER GENERAL DRIVEWAY LOCATION CONSIDERATIONS

Driveways should be as far as possible from major intersections.

Even though the determination of the full “functional area” of an intersection may be debatable, here are some important points to help in the driveway placement decisions near intersections.

Use the established driveway spacing standards as much as possible, for the classification of the roadway you are designing for. These standards are in **Administrative Rule Chapter 14-97** and will be known by the Department’s responsible Permitting, Planning, or Design staff person.

Where minimum corner clearance found in Rule 14-97.003(1)(i) cannot be met, due to specific site conditions, you should at least try and get 125 to 230 feet of corner clearance. In these cases it is most important to prohibit (or limit) left turns from these driveway locations.

**Driveways should be as far as possible from major intersections.** This allows for the best operations of traffic exiting the driveway and positioning itself in the intersection. It also allows the driveway to operate better because long queues are not blocking the driveway.

Corner clearance is measured like driveway separation, from the closest edge of the driveway connection to the closest edge of the parallel roadway.

**Exhibit 58  
CONNECTION SPACING  
AND CORNER  
CLEARANCE**

Access Class <i>Rule 14-97</i>	Connection Spacing (Feet)	
	>45mph	= or <45mph
1	N/A – Freeways	N/A - Freeways
2	1,320	660
3	660	440
4	660	440
5	440	245
6	440	245
7	125	

**Exhibit 59  
DRIVEWAY  
SEPARATION AND  
CORNER CLEARANCE**

Exhibit 59 is adapted from the Standard Index 515 and shows where the driveway connections are skewed, the distance would be measured from a projected edge of pavement.

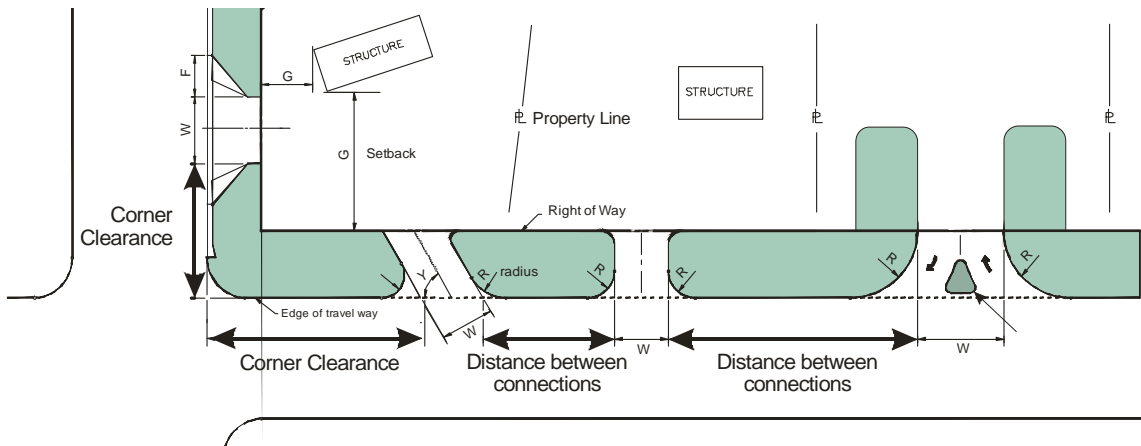

## 9.4

### DRIVEWAY SEPARATION AND THE AASHTO GREEN BOOK

#### Benefits of Driveway Separation

Driveways should also be avoided along exclusive right turn lanes

According to the latest research reported in the *AASHTO Green Book (2001)*, (page 734, Exhibit 9-101), if the operating speed is 45 mph or above, a separation of 300 feet between access points, gives acceptable urban operation. On the average, traffic using driveways with 300 foot separations usually result in an interference with 15% or less of the through traffic.

Driveways should also be avoided along exclusive right turn lanes especially where left-turn-in vehicles would regularly be let through by “Good Samaritans” in the through lane queues and then be hit by free flow vehicles in the right-turn. These free flow vehicles cannot be seen due to the queued vehicles in the through lanes.

Exhibit 60  
**AVOID MEDIAN  
OPENINGS ACROSS  
RIGHT TURN LANES**

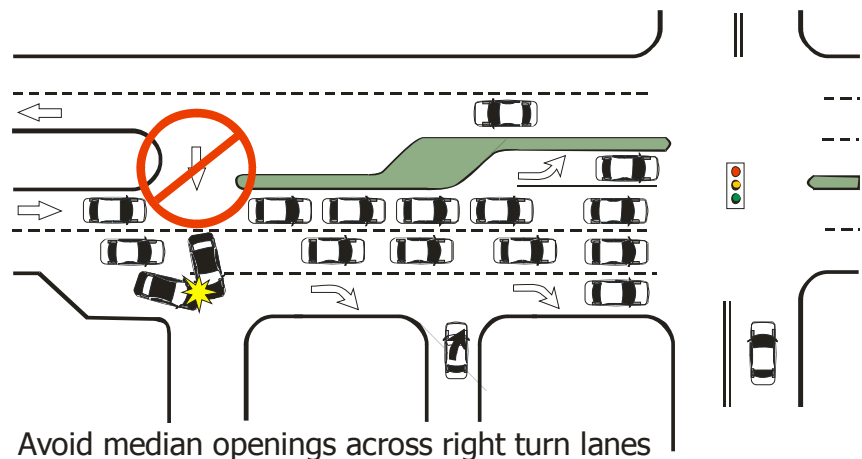



## 9. 5

### CORNER CLEARANCE DOWNSTREAM ON A MINOR SIDE STREET

It is important to think of the operational impacts of driveway placement on side streets. The operational character of the traffic turning from the main street on to the side street, as well as the expected queues on the side street, help determine how far downstream you should place the closest side street driveway.

Similar to the placement of a driveway on the main roadway, you must consider the conflicts for the exiting vehicles from the side street driveway. For the right turn out (flow A) you must consider the vehicles approaching on the left (flow C). The greater the radius for right turn vehicles from the main roadway, the faster they will be approaching the side street driveway. For the driver exiting the side street driveway to go left (flow B), you must consider the length of the queue at the main intersection to assure there is enough room to turn left from the driveway, not being blocked by queue D.

It is for that reason that the driveway should be located a reasonable separation as shown in the table.

Exhibit 61  
**DOWNSTREAM  
CORNER CLEARANCE**

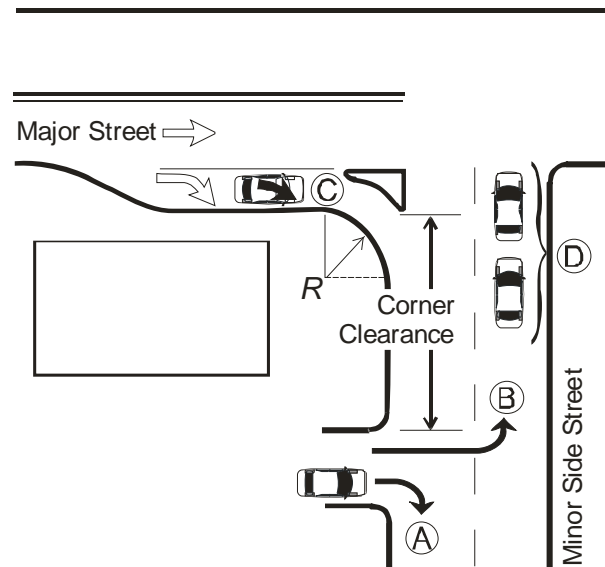

Exhibit 62  
**DOWNSTREAM  
CORNER CLEARANCE  
FOR SIDE STREET**

Radius (feet)	Minimum Suggested Corner Clearance (Feet)
50' and no channelization	120'
50' with channelization	200'
75' with channelization	230'
100' with channelization	275'

## 9.6

### DRIVEWAY PLACEMENT AND MEDIAN OPENINGS

Driveways should never be located where it is necessary for left turning vehicles to cross an intersection's left turn lane such as shown below:

Exhibit 63  
**NO MEDIAN OPENINGS ACROSS LEFT TURN LANE**

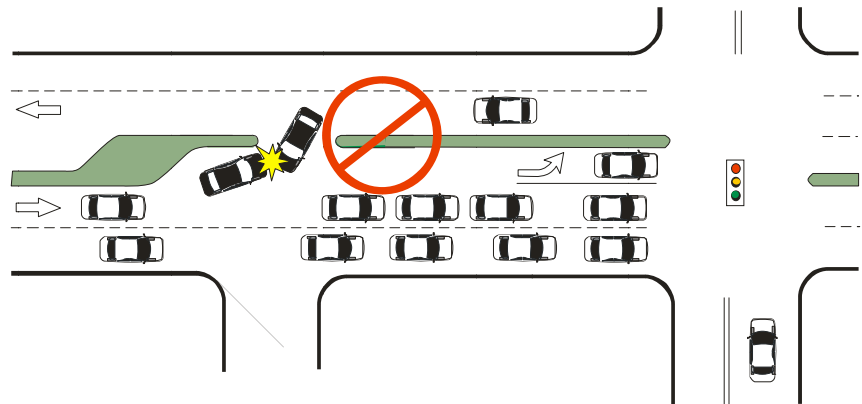
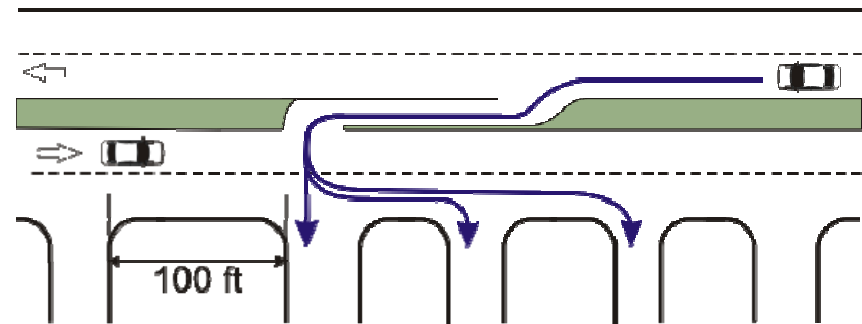

Exhibit 64  
**ENTRY MANEUVERS FROM A U-TURN**



Driveways either across or downstream from median opening

Driveways should be located directly opposite, or downstream, from a median opening as illustrated. Where it cannot be directly across, driveway access should be located more than 100 feet upstream from the median opening to prevent wrong way maneuvers as seen in Exhibit 64.

#### Extra Driveway Area for U-turns

It is sometimes necessary to provide extra pavement at a driveway or to allow easier U-turns at a median opening. Where you have a 4-lane roadway and there is a driveway across from it, consider a design similar to the one shown in Exhibit 65 to allow the ease of this movement.

Exhibit 65  
U-TURNS

Providing extra driveway pavement across from median openings can help U-turn movements. This would typically be done on 4-lane roads

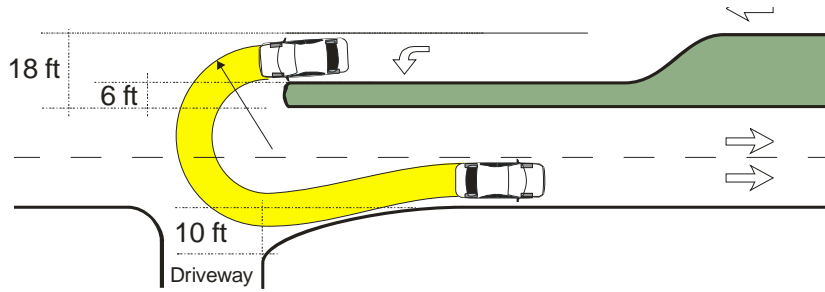

9.7

DRIVEWAY  
PLACEMENT IN  
INTERCHANGE AREAS

*Turning volumes and change in speed ... place unique operational demands on the crossroad facility.*

Access management on interchange crossroads deserves special attention because turning volumes and change in speed from acceleration and deceleration maneuvers place unique operational demands on the crossroad facility.

**Administrative Rule 14-97.003** states the importance of regulating access on freeway crossroads. In order for high speed and high volume freeways to operate at optimum level, we must assure smooth operation of freeway interchanges with at-grade arterials roadways.

**Administrative Rule 14-97.003** considers the space within a quarter mile from any of the quadrant's ramps to be an area of special concern. It further states that where the posted speed on the arterial is 45 mph or less, we will restrict the closest driveway to at least 440 feet from the end of the off ramp. Where the posted speed limit is greater than 45 mph, the restricted area to the first permitted driveway will be 660 feet.

Even though the **Administrative Rule 14-97.003** discusses interchange area driveway separation, the required measurements in many cases, will not be enough to assure good operations in the interchange area. The Plans Preparation Manual (Chapter 2) states a minimum distance of 300 ft., however this is the minimum rural space for purchasing limited access right of way. More distance is needed from the end of limited access right of way to the first driveway, especially if left turns are permitted.

Recent analysis at the national level (*NCHRP Report 420*, 1999 and Layton-1996) shows that **750 to 900 feet may be a more appropriate minimum distance** separating a driveway (even if the driveway is only right-in-right-out) from either an off-ramp or on-ramp to a freeway.

Exhibit 66  
RAMP SPACING

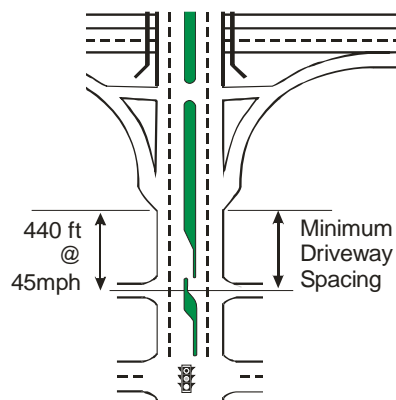

Exhibit 67  
**RECOMMENDED  
 MINIMUM DRIVEWAY  
 SPACING BEFORE AN  
 ON OR OFF-RAMP**

Area Type	Assumed Speed (Mph)	Rule Chapter 14-97.003	Recommended Minimum Spacing
Urbanized	35	330 ft.	750 ft.
Transitioning	45	660 ft.	750 - 900 ft.
Rural	55	660 ft.	900 -1,200 ft.

Source: The recommended minimum spacing is from NCHRP Report 420

9. 8

**ACCESS CONNECTIONS  
 ON OPPOSITE SIDES  
 OF A ROADWAY  
 (OFFSET)**

Closely spaced driveways on opposite sides of an undivided roadway or a roadway with two-way left-turn lane (TWLTL) result in “jog” maneuvers, instead of separate and distinct left-turn and right-turn maneuvers (see Exhibit 68). They can also result in conflicting left-turns. Separation of the access connections results in their functioning as separate T-intersections (3-way intersections) that have relatively low crash potential.

Exhibit 68  
**AVOID JOG MANEUVERS**

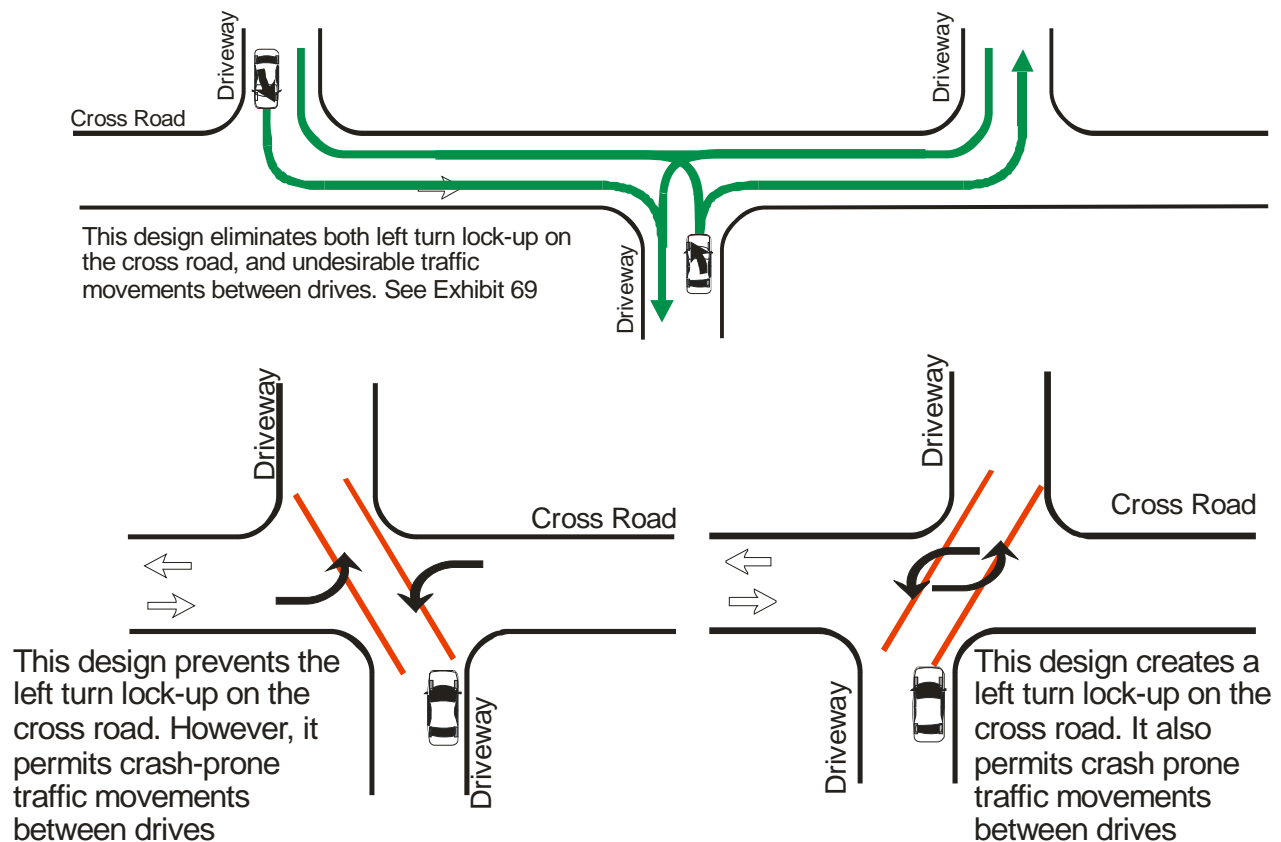

Exhibit 69  
**THE RECOMMENDED  
 OFFSET DISTANCES  
 FROM MICHIGAN DOT**

The following figure and table from the *Michigan Access Management Guidebook* shows different configurations of offset with traffic operational evaluations from best to worse.

<b>Desirable Offset Distance</b> Between Low to Medium Volume Access Points (such as residential streets) on Opposite Sides of the Roadway on Undivided or TWLTL Highways (in Feet)	
<b>Posted Speed MPH</b>	<b>Offset Distance (feet)</b>
25	255
30	325
35	425
40	525
45	630
50	750

Source: Michigan DOT, Traffic & Safety Division Notes 7.9C

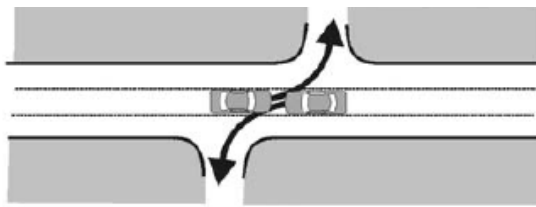

Exhibit 70

Source: Michigan Access Management Guidebook, Planning & Zoning Center, Inc.



## 9.9

### DRIVEWAYS NEAR BUS STOPS AND FOR TRANSIT FACILITIES

#### Interaction Between Modes

Also [See Chapter 10](#) for Driveways and the Pedestrian Environment

Bus stop locations can have a major impact on the operations and visibility of driveways. This is even more important in locations where buses may lay over, since the sight distance may be blocked for more than a few moments. If a poorly positioned driveway cannot be moved, work with the local transit authority to possibly move the bus stop.

When transit is present, avoidance of conflicts between transit, transit passengers, and other modes must be the primary consideration. The first step, in locating a driveway in the vicinity of a bus stop, is to consider the interaction of the bus with other vehicles and pedestrians. It is important to identify and analyze any potential hazards and vulnerabilities that could lead to an accident. Can the bus operator see the vehicles entering and exiting the driveway? Like trains, many people think they can “outrun” a bus. Can the bus driver and the people using the driveway see the people waiting for the bus? Do the people using the driveway have sight distance to be able to see oncoming buses? The landscape and facility design for entrances and exits to lots which are used by both vehicles and buses should not allow for unnecessary obstruction to clear lines of sight. The landscaping should be clear from 3-10 feet in height.

A stopped bus should not block a driveway if it is the only access and egress to the lot. Severely restricted sight distance and potentially hazardous oncoming traffic conflicts could arise if the only other available driveway is in front of the stopped bus. When considering a bus stop in relationship to a driveway it should be noted that a typical bus is 40 feet in length and an articulated bus is 60 feet in length. It is important to coordinate with the local transit agency on this issue. For more information see the ITE publication:

- ***Accessing Transit Design Handbook for Florida Bus Passenger Facilities***, FDOT Public Transportation Office (2004)
- ***Proper Location of Bus Stops or the Transit Cooperative Research Program (TCRP) Report 19*** study addressing: *Guidelines for the Location and Design of Bus Stops*.
- ***FDOT District 4 Transit Facilities Guidelines*** may also be a useful reference.

Exhibit 71  
**BUS STOP/DRIVEWAY  
 ARRANGEMENTS**

Source: adapted from District 4  
 Bus/Transit Guidelines

Below are some diagrams that point out some of the acceptable and undesirable bus stops in relation to driveways.

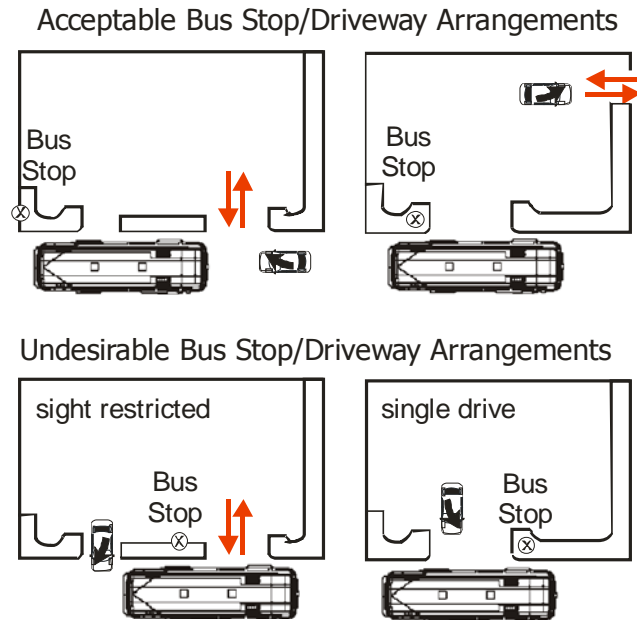

Source: Adapted from *Summary of Guidelines for Bus-Related Street Improvements* - Kay Fitzpatrick and Thomas Urbanik II - *ITE Journal*, November 1991 – Nationally published in the *Transit Cooperative Research Program Report 19 – Guideline For The Location And Design Of Bus Stops*

Sidewalks, Driveways and  
 Bus Shelter Considerations

Care should be used when considering the pedestrian impacts to a bus stop/shelter being placed next to a driveway. Frequently, pedestrians walking past a bus stop will go around the bus stop and that may take them out of the sight line of drivers using the driveway.

Separation of Modes For  
 Park/Kiss/Bike And Ride  
 Facilities

Individual and transit access should be organized within the park-and-ride facility to minimize conflicts and maximize the efficiency of the various operations. This can be achieved by providing separate access driveways for transit and non-transit modes such as short-term waiting (kiss-and-ride) or long term (park-and-ride or bike-and-ride) activities. If a common access point must be used, a transit-only boarding area for transit patrons should still be provided, with automobile traffic directed to the lot via a separate internal lot entrance. A number of potential schematic layout concepts have been used that provide these features.



The driveway location design should not create an obstacle to pedestrians or interfere with visibility between the transit loading zone and the parking lot. Some lot layouts are presented in Exhibit 72.

**Exhibit 72  
PROTOTYPE BUS  
FACILITIES**

*Source: Accessing Transit Design Handbook for Florida Bus Passenger Facilities (2004)*

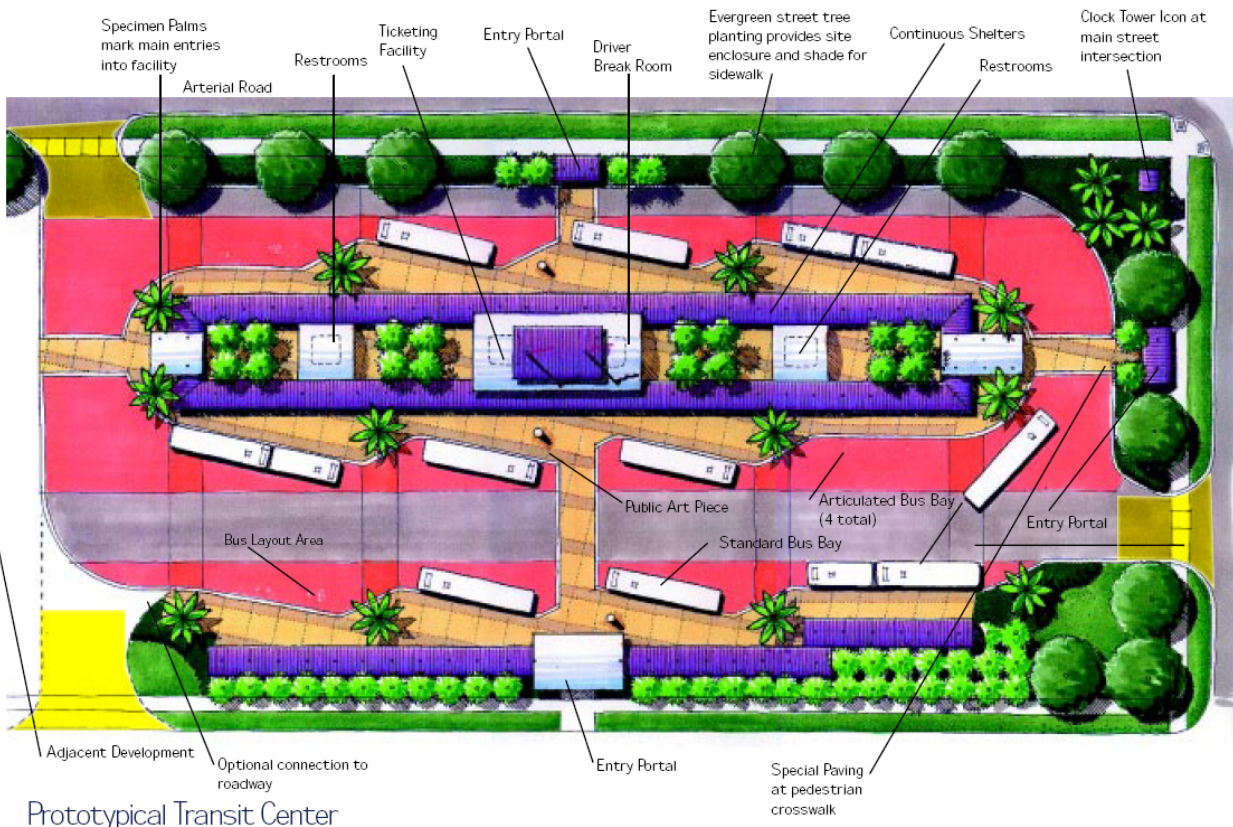
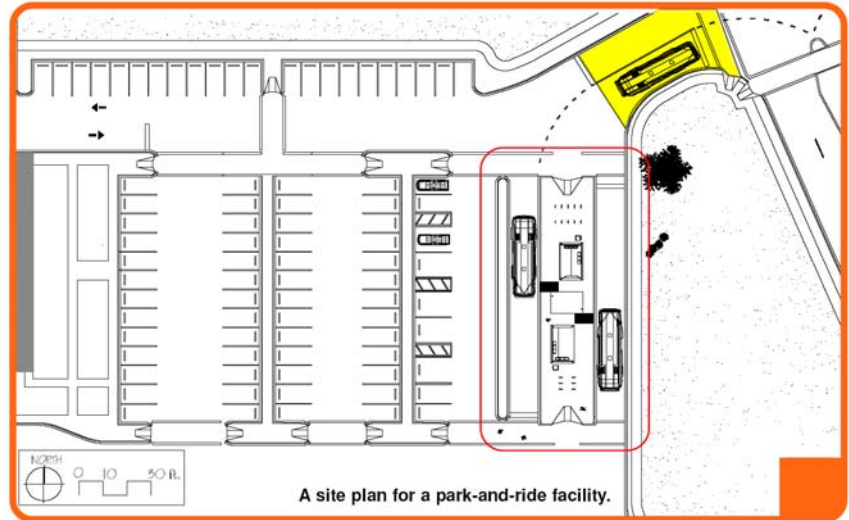

**Sight Distance for buses**

For each driveway exit, the critical design vehicle using the driveway and local street and roadway standards will determine the required sight distance. For driveways used primarily by transit, the transit vehicle should be held as the critical design vehicle because of its slower acceleration capabilities.

Placing Driveway Access to Transit Facilities

Because inbound access to the park-and-ride lot is perceived by the user as more critical than outbound movement due to the tendency of patrons to arrive with few minutes to spare, inbound access efficiency should be maximized. However, it is typically in the evening peak that the facility demonstrates the greatest external impacts on the surrounding transportation network because of the large platoons of vehicles trying to leave the park-and-ride lot at the same time (e.g., shortly after a transit vehicle arrives at the lot).

Driveways for park-and-ride facilities should be located to provide preferably 350 or more feet between successive entrances, and not be placed closer preferably 350 or more feet to any street intersection. Two combined entrances and exits should be considered for lots in excess of 300 spaces.

Turning Traffic Across Bus Lanes, HOV Lanes, And Driveways

Vehicles may enter a right curb bus or HOV lane in order to complete a right turn into or out of a crossing street or driveway; they should not turn directly into or from the second lane. A distance of 300 ft upstream and downstream of the entrance is adequate and appropriate.

Driveways on Contra flow lanes

In the case of a contra flow lane of any type (right curb, left curb, median). Informational signs should be used at frequent intervals, particularly at major driveways.

## 9.10

### SHARED DRIVEWAYS AND INTERNAL SITE INTERCONNECTION

#### Exhibit 73 JOINT AND CROSS ACCESS

Avoid

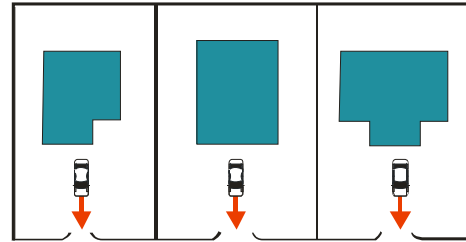

Promote

- Cross Access
- Joint Access
- Complete on-site circulation

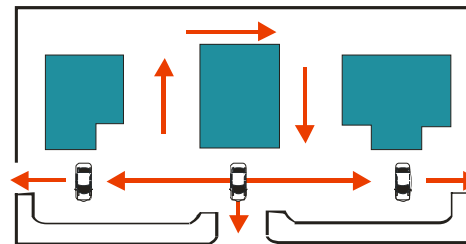
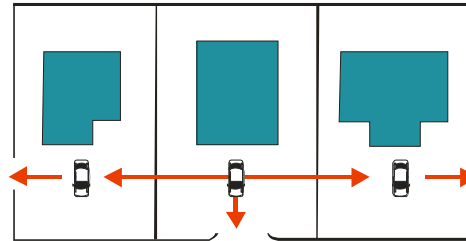

Source: “[Managing Corridor Development, A Municipal Handbook](#)”, Center for Urban Transportation Research, University of South Florida, October 1996. Williams, Kristine M. and Marshall, Margaret A.

Sharing driveways and providing cross parcel access has two benefits. The first minimizes the number of driveways on the arterial road. Providing cross access between properties broadens the access choices for the driver.

If a group of smaller developments share access, the driver needing to turn left across heavy volumes can usually find an access that is signalized, allowing safer left turns. Having good cross parcel access also maximizes the number of well designed unsignalized driveways that have good visibility and are located in such a way to take advantage of sufficient gaps in traffic from a nearby signal. Joint driveways and cross access especially help the small corner lots and out parcels. On small corner parcels left turn accessibility is a problem due to the fact that the left turns all conflict with the functional area of the intersection.

Exhibit 74  
**JOINT AND CROSS  
ACCESS PROVIDES  
DRIVERS WITH  
BETTER LEFT TURN  
ABILITY**

Getting people to signals for left turns across high volume roads is critical!

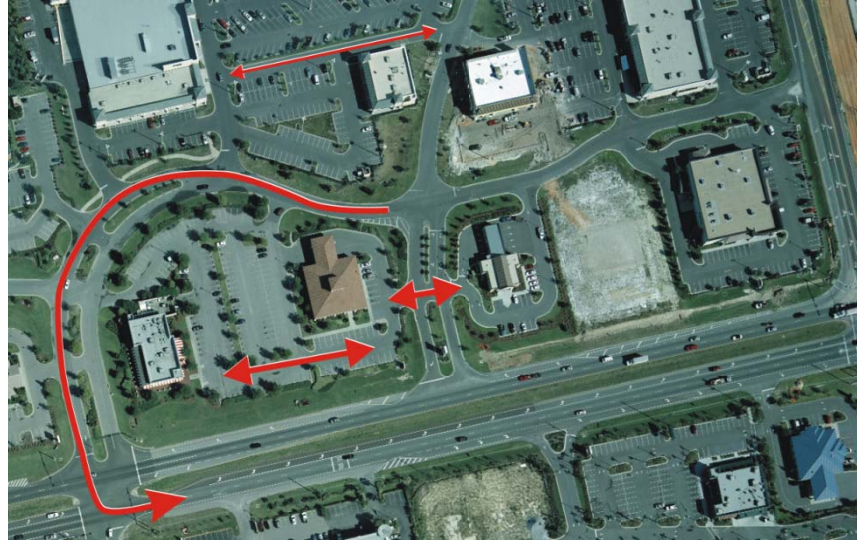

Interconnected developments give customers and deliveries more options, especially for safe left turns.

It is easier to provide cross and joint access if it is planned at the beginning of a development process. At that time you will have the ability to layout access systems and allow good separation between these accesses. Many local governments have already addressed these issues in their land development regulations by providing requirements for joint and cross access with large neighboring developments and small corner out parcels.

Exhibit 75  
**DRIVEWAY LENGTH**

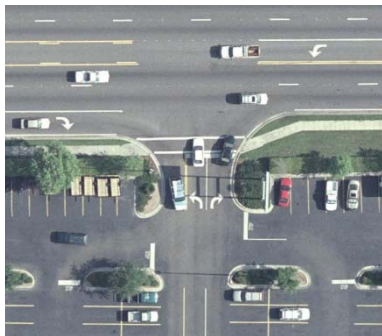

There are some challenges associated with joint and cross access in retrofit situations. In these situations you are usually dealing with a group of small shallow land parcels where joint access has never been considered in the past. One of the major problems associated with producing new joint and cross access is that the cross access points are often close to the driveway entrances. This proximity may prevent having adequate driveway depth ([See Chapter 6 Driveway length](#)). In retrofit situations you should consider the volume of traffic using these driveway entrances and exits and the volume of traffic crossing close by to determine whether these situations with a relatively shallow driveway depth will cause an internal traffic circulation difficulty. Signing and landscaping may also help in these tighter situations on cross access in retrofit situations.





## DRIVEWAYS AND THE PEDESTRIAN ENVIRONMENT

### 10.1

#### THE PEDESTRIAN AND THE DRIVEWAY ENVIRONMENT

Almost all access management designs and operational strategies impact pedestrians and bicyclists. In general, pedestrians and bicyclists need to be considered where they cross major streets and driveways. Where vehicles cross significant pedestrian traffic or bicycle facilities, the design should accommodate vehicles at lower speeds. The following strategies promote pedestrian and bicycle travel and safety.

Some general principles of accommodating pedestrian and the driveway are:

- Minimizing higher speed vehicle/pedestrian conflicts.
- Preventing driveway slopes from encroaching into the sidewalk, which may present a problem for the elderly or persons in wheelchairs or on walkers.

Driveway crossings should be designed so that both the pedestrians and the drivers are able to use them safely. When the path of the motorist crosses the pedestrian's path of travel, significant cross slopes can result, (see exhibit 76) and the pedestrian or wheelchair user must negotiate changes in cross slopes.

Hard contact with both rear wheels of a wheelchair is necessary to steer the wheelchair through a transition. Abrupt transitions may cause the wheelchair user to lose control and possibly tip over. **Therefore, whenever possible, driveway crossings without level landings (or "walk arounds") should be replaced.**

Exhibit 76  
**AVOID ABRUPT  
TRANSITIONS**

When cross-slopes change rapidly over a short distance, wheelchair use becomes extremely unstable.

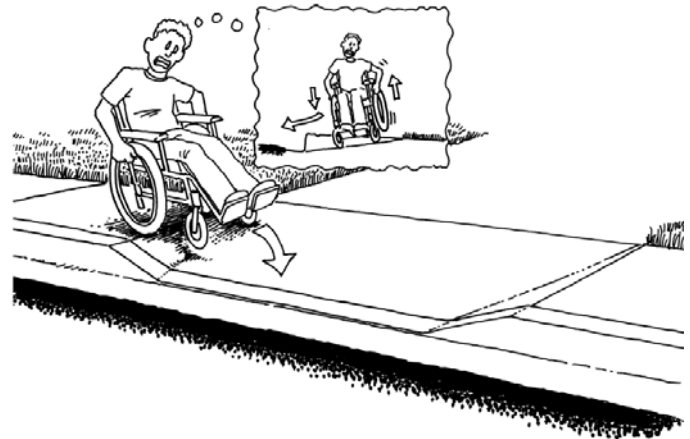

*Source: Designing Sidewalks and Trails for Access (Part 1) USDOT 2000*

Driveway Width & Spacing

Longer driveway spacing reduces conflicts and hazards.

If the driveway crossing is too wide, if driveways are frequent, or if the entry and exit speeds are high, the pedestrian faces substantial discomfort and risk. Every driveway creates potential conflicts. **Reducing the number of driveways reduces the number of pedestrian/vehicle conflict points.**

## Sidewalk Location

**Locating sidewalks away from the curb offers many operational and safety benefits.** If the buffer strip (called the “utility strip” in the Standard Index) is of an adequate width, drivers can pull completely out of the traffic stream before yielding to a pedestrian (see exhibits 77 and 78). Pedestrians are separated from street traffic and better protected. However, the location of the stop bar can be a problem if located too far back from the intersecting cross street.

Exhibit 77  
**“WALK AROUND”**  
*Jogging the sidewalk back from the street provides a level landing for pedestrians on narrow sidewalks*

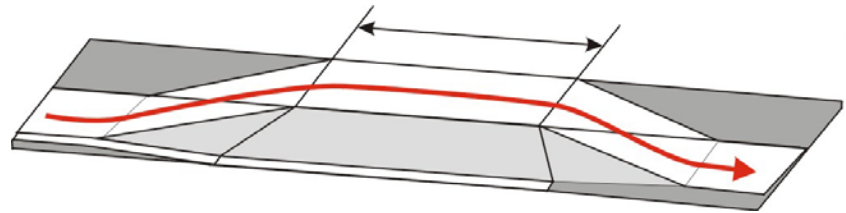
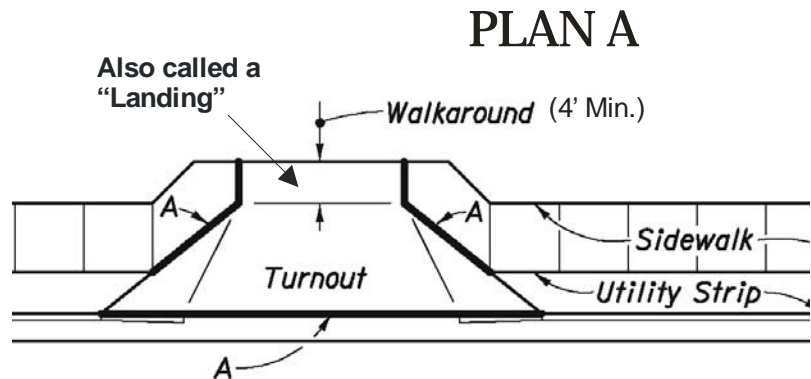

Exhibit 78  
**4 FT WALKAROUND**  
*Source: Standard Index 310*





Benefits of wider landscaped areas or utility strips

Provide enough space to maintain grass and other landscaping. Wider landscaping strips are usually easier to maintain than very narrow strips. A 5 ft. or greater buffer/utility strip would place the sidewalk far enough back so that the driveway slope does not encroach into the sidewalk. This also minimizes the slope for vehicles using the driveway.

Exhibit 79  
**UTILITY OR BUFFER STRIP**

*When sidewalks have a planter strip, the ramp of the driveway does not interfere with a pedestrian's path of travel.*

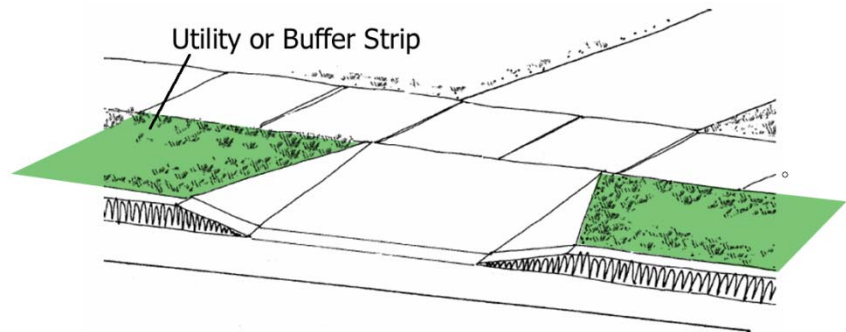
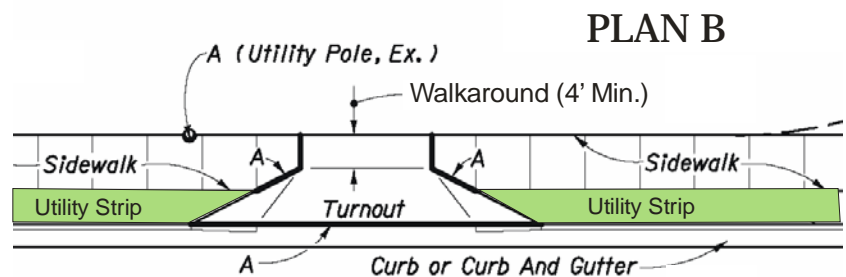

Exhibit 80  
**WALKAROUND (WITH UTILITY STRIP)**  
*Source: Standard Index 310*



Right turn lanes

Right turn lanes can reduce speeds at the sidewalk crossing and reduce conflicts and confusion. Right turn lanes provide a dedicated space for vehicles to decelerate and turn using a smaller turn radius. This allows for slower turning speeds and more narrow crossings for pedestrians. This can also provide a location for right turn vehicles to wait for pedestrians to cross the driveway.

## 10.2

### PEDESTRIAN SAFETY IN DRIVEWAY DESIGN

Left turns into driveways can cause additional conflicts with pedestrians. A median in the roadway is necessary to assure this left turn movement restriction. Driveways that attempt to restrict left turns by use of channelization only through the use of a small “pork chop” don’t usually succeed in restricting the left turn movements.

#### Left turns into driveways

Roadway medians offer areas of safe refuge to pedestrians crossing the street. Pedestrian crash rates are lower on roads with raised medians than on undivided highways or those with continuous two-way left turn lanes.

The right-turn only driveway design may use a raised channelized island in the driveway area. To provide for the pedestrian, use a full wheelchair accessible cut allowing the pedestrian to cross and stand in this space. The width of this island should be at least 6 feet to assure safety for pedestrians in wheelchairs

#### Downtown Areas

Driveways in true downtown areas should be infrequent, especially where pedestrian-oriented design is used. However, in some downtown locations, parking garages, parking lots, and other driveways exist, but usually on side streets. In these cases, driveways should be relatively narrow and designed for lower-speed entry (5-8 mph). It is preferable to have garage driveway openings on side streets where these crossing conflicts affect fewer pedestrians.

*Source: Florida Pedestrian Planning and Design Handbook (1999)  
FDOT Traffic Operations*

### 10.3

#### FDOT DRIVEWAY AND SIDEWALK DESIGN CRITERIA

FDOT guidance for sidewalk design adjacent to curbed roadways is found in **Standard Index 310**, Concrete Sidewalk, and **Standard Index 515**, Turnouts. **Standard Index 310** shows plan views of a sidewalk with and without a utility strip and includes guidance for the sidewalk area (walk around) through the driveway (turnout) and cross slope requirements. The walk around segment of the sidewalk is handled in two different ways. First, the edge of the walk around lies on the existing right of way line. For this case, grade of the driveway and width of the sidewalk is adequate to handle the proper design. Second, the edge of the walk around segment extends past the right of way line and in turn would require more right of way. This situation would occur if more depth would be required of the driveway to handle an inadequate grade or, where a narrow sidewalk may exist. **Standard Index 515** contains all driveway information including cross slope requirements and applications for general, marginal, and adverse applications.

Source: Standard Index 310

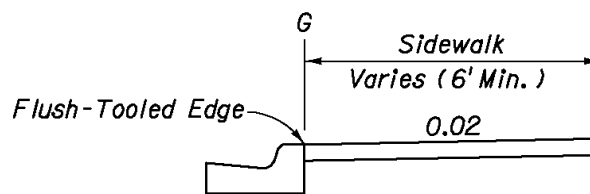
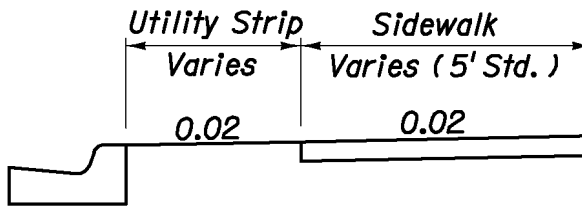

## Detectable Warning Surfaces

To assist pedestrian with visual impairments, detectable warning surfaces/truncated domes are to be placed at the location where the sidewalk meets the driveway in the following conditions:

- The driveway width is 24 ft or greater on a flush (rural) section (from *Standard Index 310 Sheet 2*), or
- The sidewalk is at a different level than the driveway, or
- Special circumstances such as one way driveways narrower than 24 ft., or
- Anywhere that the Detectable Warning Surfaces would best serve the safety of the public.

The purpose of the truncated domes is to provide a warning to the pedestrian who is visually impaired. Details on the truncated domes and curb ramps are found in *Standard Index 304 and Index 310*.

### Exhibit 85 DETECTABLE WARNING SURFACES

Source: *Standard Index 310*

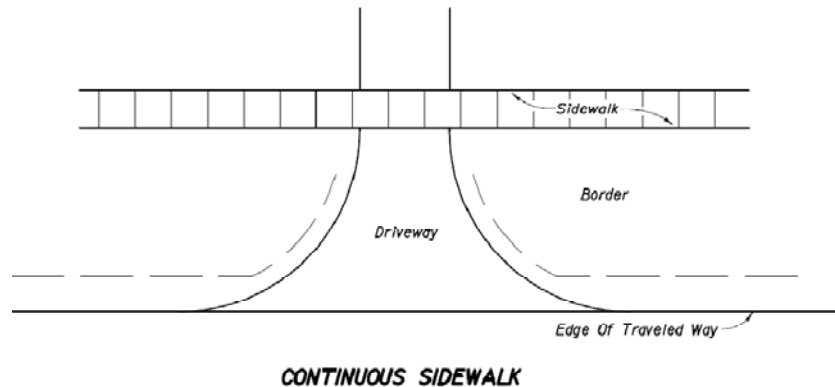

#### **Note 2. from Index 310**

*Sidewalks adjoining driveways 24' and wider, right in-right out composite driveways and side roads and streets shall have a detectable warning surface that extends the full width of the sidewalk and in the direction of travel 24" (610 mm) from the edge of driveways and edge of side roads and streets. Detectable warning surfaces shall conform to the requirements described in the General Notes on Index No. 304.*

*For sidewalks continuous through driveways, detectable warning surfaces are not required.*

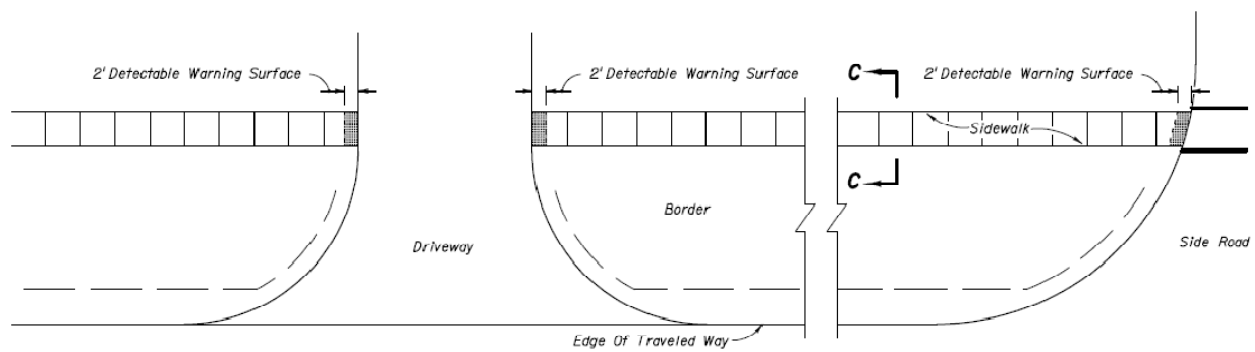

**DISCONTINUOUS SIDEWALK  
PLAN**

## 10.4 STRIPING FOR EXCLUSIVE RIGHT- TURN LANES WITH BICYCLE LANES

Discussion of pedestrian  
and cyclist concerns

Right turn lanes can be beneficial or limiting to pedestrians under certain situations. Where there are heavy pedestrian volumes crossing sidewalks and side streets coupled with heavy automobile traffic, the right turn lane actually gives protection to the pedestrian crossing the driveway or side street, because the right turn vehicle is in a protective location and does not feel pressure to try to beat the pedestrian to the driveway crosswalk.

Where the right turn lane may not be beneficial to the pedestrian is for the pedestrian crossing the main street. The exclusive right turn lane will add over 12 feet of extra pavement for the pedestrian crossing the main street.

The other concern is for bicyclists in areas of exclusive right turn lanes since all new bicycle paths in Florida are on the side of the curb lane and follow through signalized and unsignalized intersections. The provision of a right turn lane puts the cyclist in a position where vehicles are passing the cyclist on both sides (on the through curb lane and on the exclusive right turn lane). Though this is correct design, too many right turn lanes in a short distance would not be optimal.

Exhibit 86  
**BIKE LANE STRIPING**

Source: *Standard Index*  
17346 (sheet 12)

